

**GENERAL PURPOSE
COMMUNICATIONS RECEIVER**

MODEL SP-600-JX

AND

MODEL SP-600-J

INSTRUCTIONS

ISSUE 6 — MAY, 1956

Manufactured by

THE HAMMARLUND MFG. CO. INC.

460 West 34th St.

New York 1, New York, U.S.A.

GENERAL PURPOSE COMMUNICATIONS RECEIVER

MODEL SP-600-JX

AND

MODEL SP-600-J

INSTRUCTIONS

MODEL SP-600-J

The Model SP-600-J Receiver does not have the Frequency Control Unit. When this Instruction Book is used in connection with the Model SP-600-J Receiver, all indications in the text, photographs and diagrams, with reference to the Frequency Control Unit, should be ignored as they do not apply. With this exception the two models are identical.

ISSUE 6

Manufactured by

THE HAMMARLUND MFG. CO. INC.

460 West 34th St.

New York 1, New York, U.S.A.

Printed in U. S. A.



FIG. 1
FRONT VIEW OF RECEIVER
SP-600-JX IN CABINET

TABLE OF CONTENTS

Title	Page
Technical Summary	4
I General Description	5
II Circuit Description	6
III Installation	7
IV Operation	8
V Maintenance	10
VI Alignment	16
VII Conversion of Table Model Receiver for Rack Mounting.....	20
Table 1—Tube Socket Voltages.....	14
Table 2—Tube Socket Terminal Resistances.....	15
Table 3—RF and HF Oscillator Alignment Frequencies.....	17
Table 4—Approx. Signal Inputs at IF and AF Stages.....	17
Table 5—Parts List	21
VIII Supplements to cover Models SP-600-JL, SP-600-JLX and SP-600-J25	40

ILLUSTRATIONS

Figure 1 Front View of Receiver SP-600-JX, in cabinet.....	2
Figure 2 Block Diagram	7
Figure 3 Location of Tubes and Adjustments.....	18
Figure 4 Audio and Overall Fidelity Curves.....	18
Figure 5 Selectivity Curves	19
Figure 6 Rear View of Receiver.....	25
Figure 7 Top View of Receiver.....	26
Figure 8 Top View of Receiver—Capacitor Shield and Spare Fuse Cover Removed.....	27
Figure 9 Bottom View of Receiver—Tuning Unit Shield Removed.....	28
Figure 10 Bottom View of Receiver SP-600-JX.....	29
Figure 11 Bottom View of RF Tube Platform.....	30
Figure 12 Bottom View of Frequency Control Unit.....	31
Figure 13 Circuit Diagram of Receiver.....	33
Figure 14 Connection Diagram—Receiver Chassis.....	35
Figure 15 Connection Diagram—Tuning Unit.....	37
Figure 16 Connection Diagram—Frequency Control Unit.....	39

GENERAL PURPOSE COMMUNICATIONS RECEIVER

MODEL SP-600-JX

TECHNICAL SUMMARY

Electrical Characteristics

Frequency Range—total 6 bands.....	.54 to 54.0 mc
Band 1.....	.54 to 1.35 mc
Band 2.....	1.35 to 3.45 mc
Band 3.....	3.45 to 7.40 mc
Band 4.....	7.40 to 14.8 mc
Band 5.....	14.80 to 29.7 mc
Band 6.....	29.70 to 54.0 mc

Power Output—2.0 watts, with less than 10 percent distortion.

Output Impedance—600 ohms-balanced split windings.

Phone jack-winding; delivers 15 milliwatts to an 8000 ohm resistive load, when the audio output to the 600 ohm power load is adjusted to 500 milliwatts.

Power Supply Requirements

Line Rating..... 95, 105, 117, 130, 190, 210, 234 and 260 volt taps, 50-60 cycles.
Power Consumption..... 130 watts, 1.25 amps. at 117 volts—maximum.

Tube Complement—total 20

RF, IF and BFO Amplifiers.....	7 — 6BA6
HF, 2nd Conversion and BFO Oscillators.....	3 — 6C4
Crystal Controlled HF Oscillator.....	1 — 6AC7
Mixers.....	2 — 6BE6
Detector, "C" Bias Rectifier and Noise Limiter & Meter Rectifier.....	3 — 6AL5
AF Amplifier and IF Output.....	1 — 12AU7
Power Output.....	1 — 6V6GT
Rectifier.....	1 — 5R4GY
Voltage Regulator.....	1 — 0A2

Mechanical Specifications

Rack Model—Dimensions; 19 inches wide, 10½ inches high and 16½ inches deep from rack mounting surface. Weight 66 lbs.

Table Model—Dimensions; 21¾ inches wide, 12¾ inches high and 17⅛ inches deep. Weight 87½ lbs.

Performance Data—(approximate values-taken on a sample receiver)

Sensitivity is 2.3 microvolts, or better, throughout the entire frequency range, for a signal to noise ratio of 10 db, at 20 milliwatts output and with the RF Gain Control at maximum.

Image rejection ratios are better than 74 db throughout the frequency range.

The IF rejection ratio at 600 kc is 2700 to 1.

The AVC action will maintain the output constant within 12 db when the input is increased from 2 to 200,000 microvolts.

GENERAL PURPOSE COMMUNICATIONS RECEIVER

I

GENERAL DESCRIPTION

The SP-600-JX is a 20 tube Radio Communications Receiver with self contained power supply. The J suffix in the model number denotes that this receiver is made using components having characteristics which are the equivalent of military component specifications insofar as is practicable.

The receiver is supplied in either a well ventilated steel, table model cabinet finished in dark grey to complement the lighter grey front panel or for mounting in a standard 19 inch relay rack.

The self contained power supply is designed for operation from a single phase, 50 to 60 cycle alternating current power source. The power transformer primary is provided with taps covering a line voltage range from 90 to 270 volts. The power consumption is 130 watts.

The receiver is suitable for either headphone or loudspeaker reception of AM radio telephone, CW telegraph, AM MCW telegraph signals and for diversity applications.

The standard model provides continuous coverage over a frequency range from 0.54 to 54.0 megacycles in six bands. The large easily operated band change control knob, on the front panel, selects the desired frequency band and a band indicator visible through a small front panel window indicates the frequency band in use. This control also aligns the dial frequency indicator with the proper dial scale.

In addition to the frequency scales, the main dial has an arbitrary scale which in conjunction with the vernier dial provides continuous expanded scales over each frequency band for extremely accurate logging and resetability.

The single tuning control is large and of special design to permit maximum traverse speed as well as exceptional operating ease. It controls both the main and vernier dials. An anti-backlash gear train provides extremely close calibration accuracy and completely accurate resetability. A tuning lock provides positive locking action without affecting the frequency setting.

The tuning ratio from the tuning control to the main dial is 50 to 1 and the ratio from the vernier dial to the main dial is 6 to 1.

Two stages of radio frequency amplification are provided on all bands. Single conversion is used for signal frequencies up to 7.4 mc and double conversion, employing a crystal controlled oscillator, for signal frequencies above 7.4 mc. Four stages of IF amplification, detector and AVC rectifier, noise limiter and meter rectifier, beat frequency oscillator and buffer

amplifier, IF output, AF amplifier and output power stage are provided.

The frequency control unit provides for fixed channel crystal controlled operation on any six frequencies within the range from .75 to 54 mc. Front panel controls permit the selection of the normal high stability continuously variable tuning or either of the six selected fixed frequency signals. For crystal controlled fixed channel operation it is only necessary to set the dial to the signal frequency, switch to the crystal frequency desired and tune with the delta frequency control. These crystals are not supplied with the receiver, but may be purchased on special order from HAMMARLUND MFG. CO. specifying the signal frequency for which each is to function.

The noise limiter circuit effectively limits the interference from ignition systems or other sources of pulse type noise. The limiter switch permits optional use of the limiter.

The antenna input circuit is designed for use with a balanced line. The input impedance is nominally 95 ohms. The receiver may also be operated with a conventional single wire antenna.

The audio output circuit is designed for a 600 ohm load or line and is provided with a four terminal split winding for balanced load operation. Maximum power output is approximately 2.0 watts. The headphone circuit when referred to an 8000 ohm load provides signals attenuated approximately 15 db below the 600 ohm power output.

The send receive switch desensitizes the receiver but leaves the power on to provide for instant reception between transmission periods.

Radiation is negligible and complies with requirements for shipboard operation and for multi-receiver installations.

Frequency drift after a 15 minute warm up period, ranges between .001 percent and .01 percent of frequency depending on the frequency used. This is a very unusual degree of frequency stability for variable tuned HF oscillators and closely approaches crystal stability.

The selectivity control provides three degrees of crystal and three degrees of non-crystal selectivity ranging from sharp (.2 kc) to broad (13.0 kc). The crystal filter embodies the same circuit features that have proved so effective and desirable in Hammarlund Super Pro Receivers, incorporated in an improved mechanical design.

CIRCUIT DESCRIPTION

General—The circuit is shown schematically in Figure 13. A block diagram, Figure 2, is provided to more clearly show the arrangement and functions of the various circuit sections. The location of the various tubes is shown in Figure 3. The circuit, for single conversion, used for signal frequencies up to 7.4 mc consists of two stages of RF amplification V-1 and V-2, First Mixer V-5, First Heterodyne Oscillator V-4, four stages of IF amplification V-7, V-9, V-10 and V-11, Detector and AVC rectifier V-14, Noise Limiter V-15, Beat Frequency Oscillator V-13, IF output and AF amplifier V-16-A and V-16-B, Output Power stage V-17 and the Power Supply system which includes B Power Rectifier V-19, C Bias Rectifier V-20 and Voltage Regulator V-18.

In the circuit for double conversion, used for signal frequencies above 7.4 mc, the Second Mixer V-6 and Second Heterodyne Oscillator V-8 are substituted for the Gate tube V-7.

Input Coupling—The antenna coupling is designed to provide optimum coupling from a 95 ohm transmission line. A balanced doublet or straight wire antenna may be used.

RF Amplifier—An ingeniously designed rotary turret is employed to change bands and to place the coil assemblies of the RF amplifier V-1 and V-2, Mixer V-5 and First Heterodyne Oscillator V-4 stages directly adjacent to their respective sections of the four gang tuning capacitor and their respective tubes. This assures maximum sensitivity at high signal to noise ratio.

First Heterodyne Oscillator—(Variable V-4)—The rotary turret band change switch, advanced design of the four gang, twin section, variable tuning capacitor and rugged construction throughout, provide frequency stability and dial calibration accuracy to a previously unattained degree.

First Heterodyne Oscillator—(Crystal Controlled V-3)—For services requiring extremely stable, fixed frequency operation, a crystal controlled high frequency oscillator is provided. Instant changeover from variable to crystal controlled oscillator with a choice of six crystal positions, is effected by a front panel control. A second front panel control permits adjustment of the crystal oscillator frequency over a plus or minus .005 percent range.

Intermediate Frequency Amplifier—Single conversion to 455 kc is employed for signal frequencies below 7.4 mc. There are four stages of IF amplification incorporating the Hammarlund patented crystal filter circuit. Six positions of selectivity provide 6 db bandwidths of .2, .5, 1.3, 3, 8, and 13 kc. On the three narrower bandwidth positions, the crystal filter is in operation. The crystal phasing control provides extreme selectivity for the high attenuation of closely adjacent interfering signals.

Double conversion is employed for signal frequencies above 7.4 mc. The signal is heterodyned to 3.955 mc by the First Mixer V-5 and Heterodyne Oscillator V-4 or V-3 for high image rejection. The 3.955 mc signal is then heterodyned to 455 kc by the Second Mixer V-6 and the 3.5 mc Fixed Crystal Controlled Oscillator V-8, for selectivity.

Detector and AVC—The V-14 tube is used as a high level Detector and AVC Rectifier. The AVC circuit is provided with separate time constants for CW and MCW operation. AVC and Diode output terminals provide for connections in diversity applications.

Beat Frequency Oscillator—The beat frequency oscillator employs a high capacity Colpitts circuit which gives a high order of frequency stability and minimizes oscillator harmonics. The beat frequency oscillator V-13, is coupled into the detector circuit through Buffer Amplifier V-12, which eliminates oscillator lock-in and permits variation of the beat oscillator injection by means of a control located on the rear of the chassis. A front Panel control varies the audio beat frequency, from zero beat to plus or minus 3 kc.

Noise Limiter—The noise limiter circuit V-15, limits the noise interference from ignition systems or other sources of pulse type noise. A separate control switch S-6, permits optional use of the limiter on any mode of operation when pulse type interference is present.

Audio Frequency Amplifier—A resistance coupled amplifier triode V-16-B, amplifies the audio frequency signal from the detector.

Audio Output—The audio output tube V-17, is transformer coupled through a split, balanced winding to deliver 2.0 watts undistorted output to a 600 ohm load. The split balanced winding permits balancing of the direct current in the output circuit, as used for teletype or similar service. A separate secondary winding provides attenuated audio signal output for head-phone operation. This winding will deliver an output of 15 milliwatts into an 8000 ohm resistive load when the 600 ohm power secondary is delivering 500 milliwatts to a 600 ohm resistive load.

IF Output—A cathode follower V-16-A provides a 70 ohm impedance source of intermediate frequency (455 kc) to socket, SO-239, on the rear skirt of the chassis. A PL-259 plug and RG-11/U cable, not supplied, are used for this connection.

Power Supply—The power supply is an integral part of the receiver. It includes the B rectifier V-19 and the C rectifier V-20, together with their respective low pass filters and the Voltage Regulator V-18. The power transformer is provided with screw terminal primary taps, covering a power line source range of 90 to 270 volts, 50 to 60 cycles. The power transformer and filter components are protected by fuses in the primary and plate supply circuits.

Tuning Meter — The tuning meter is used on AVC operation to indicate the accuracy of tuning and the relative strength of received signals. Depression of the Meter Switch converts the meter circuit for indication of output level in db from 6 milliwatts.

RF Gain Control and Power Switch — The RF gain control is provided for manual control of sensitivity to prevent overloading on strong signals when operating with the AVC-MANUAL switch in the "MANUAL" position. This control also operates when the switch is in the "AVC" position. The Power "ON-OFF" switch is operated at the counter-clockwise extremity of the RF gain control.

Send-Receive Switch — The send-receive switch desensitizes the receiver but leaves the power "on" to provide for instant reception between transmission periods.

Convenience Outlet — A convenience power outlet is provided on the rear of the chassis for the connection of an accessory such as a lamp or electric clock.

Radiation — Advanced design and shielding of the high frequency, second conversion crystal and beat frequency oscillators has reduced radiation to a negligible point so that interference of this nature, common in multi-receiver installations, is reduced to a minimum.

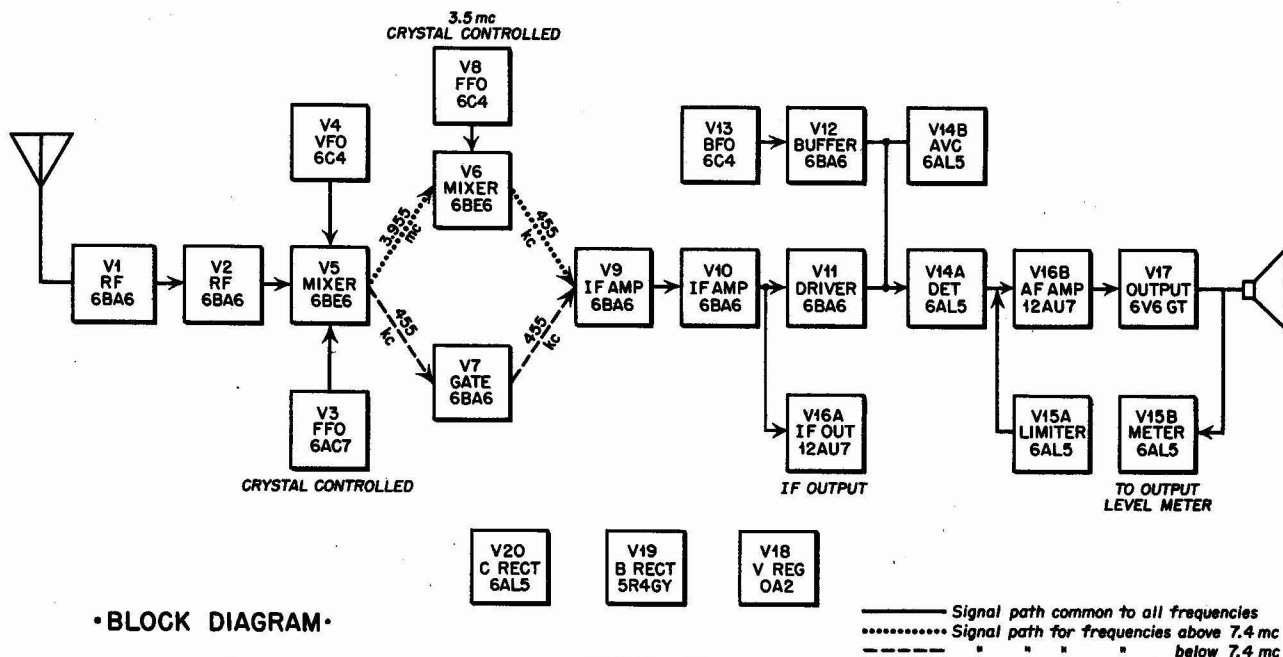

• BLOCK DIAGRAM •

FIG. 2

III INSTALLATION

Tubes and Packing — After unpacking the receiver see that all tubes are firmly in their sockets and that any packing material is removed from the receiver.

Power Supply — Make sure that the primary tap lead at the bottom of the power transformer is connected to the tap which most nearly agrees with the 50 to 60 cycle power source voltage.

Antenna — The input impedance at the antenna socket, UG-103/U, is designed to match a 95 ohm transmission line. The angle plug adapter, UG-104/U, and connector plug, UG-102/U, supplied with the receiver, are for use with RG-22/U cable which should be used with a balanced antenna installation. If it is desired to operate with a single wire antenna, the antenna lead-in wire should be connected to one terminal of the connector plug and a ground lead should be connected from the other terminal of the

connector plug to the ground terminal, which is adjacent to the antenna socket at the rear of the tuning unit.

Speaker — The speaker should be of the permanent magnet dynamic type and should include a speaker voice coil to 600 ohm line matching transformer for connection to the 600 ohm audio output terminals of the receiver. **Caution: When the 600 ohm output is not used, connect a 600 ohm, 2 watt resistor to these terminals to avoid component damage from high transient peak voltages.** For applications requiring the insertion of direct current control or indicating voltages, the jumper connecting the two balanced sections of the 600 ohm output may be removed and the insertion circuit, such as a low resistance balancing potentiometer, connected in its place.

Headphones — Either high or low impedance head-

phones may be used by plug connection to the phone jack, located at the lower left side of the front panel. The high impedance type is recommended.

Mounting—The receiver is designed for either table or rack mounting. Table models are supplied in a well ventilated steel cabinet with handles and protective rubber feet. Rack models, with top and bottom cover plates are supplied for mounting in a standard 19 inch rack. The panel is 10½ inches high. See Section VII. The receiver should be placed in a position which permits the free access of air.

Crystals for Frequency Control—Crystals, Y1 to Y6, are not supplied with the receiver, but will be supplied on special order for any signal frequency in the range of the receiver above .75 megacycle. In order to insure correct crystal controlled frequency operation, crystal units may be ordered from HAM-MARLUND MFG. CO. INC. and the order should specify the signal frequency, for which each unit is to be used. See note at end of Table 5. To install crystals, loosen the knurled thumb screw on top of the Frequency Control Unit, T34, and push the retainer spring assembly to the rear. Insert the crystal or crystals in the sockets, numbered 1 to 6. Bring the retainer spring assembly forward so that the springs press on top of the crystal holders and tighten the thumb screw. Mark the signal frequency for which each crystal was selected, in megacycles on the plastic chart provided for this purpose alongside the crystal

switch, S2. Pencil or ink may be used and can be erased if it is desired to change these figures at any time. The numerals on the chart should be used so that they agree with the numerals on the crystal socket positions, which are also indicated by the crystal selector switch.

Relay Connections—If external relay operation for the send-receive function is desired, connection may be made by soldering a twin conductor cable to the terminals of the Send-Receive switch, S9. In this case S9 is left in the Send or open position.

AVC and Diode Output—Shunt connection to the AVC bus and series connection to the detector diode load are provided at the rear of the receiver for diversity applications. The Diode Output terminals are provided with a wire jumper connection when these terminals are not used for external connection.

IF Output—The IF Output socket, SO-239, at the rear of the chassis provides for connection in diversity, teletype or other applications where a source of 455 kc, intermediate frequency is required. A PL-259 plug and RG-11/U cable should be used. This will provide an output of approximately 200 millivolts to a 70 ohm resistive load, with a normal sensitivity input of 2 microvolts signal.

Convenience Outlet—The power outlet receptacle at the rear of the chassis may be used for operating an accessory, such as an electric clock or lamp.

IV OPERATION

General—Before attempting operation of the SP-600 receiver, the operator should thoroughly familiarize himself with the functions and uses of the various controls. When referring to the controls in this description, the words in capital letters represent the part of the name adjacent to the control on the front panel or on the rear skirt of the chassis. For example, when referring to the SELECTIVITY control, the word SELECTIVITY in capitals indicates the legend appearing adjacent to the control. Reference to photographs, Figs. 1 and 6, is suggested while reading this description. Front panel controls and dials are shown in Fig. 1 and rear controls and terminals are shown in Fig. 6.

Selectivity Control—The SELECTIVITY control is a 6-position switch which selects three crystal and three non-crystal degrees of selectivity, ranging from extremely sharp for cw reception to broad for good fidelity mcw operation. The SELECTIVITY control dial indicates the 6 db bandwidth at each setting.

Phasing Control—The CRYSTAL PHASING control is a differential type, variable air capacitor. It permits adjustment of the crystal selectivity characteristic for high attenuation of closely adjacent channel interference on either side of the signal frequency.

RF Gain Control—The RF GAIN control varies

the overall gain of the receiver. This control is operative in either position of the AVC-MAN switch.

Power Switch—The power, or on-off switch is combined with the RF GAIN control. Complete counter-clockwise rotation of the RF GAIN control throws the power switch to the off position, as indicated on the RF GAIN control dial.

Audio Gain Control—The AUDIO GAIN control varies the input voltage to the audio amplifier. This control is also operative in either position of the AVC-MAN switch.

Phones Jack—The PHONES jack is a single circuit jack operating with the sleeve grounded and is suitable to receive any standard single circuit phone plug. It is in the circuit at all times and is connected to a separate secondary winding of the audio output transformer, which provides an attenuated signal for headphones. See Section III installation.

Audio Output—The AUDIO OUTPUT is available at the four screw terminal board at the rear of the chassis for connection to a 600 ohm load. See Section III installation.

Noise Limiter—The LIMITER control switches the noise peak limiter in or out of the circuit. This control is operative independently of any position of any other control. See Section II Circuit Description.

AVC-Manual Switch—In the AVC position the AVC-MAN switch applies automatic bias potentials to the controlled RF and IF amplifier tubes, thereby holding the audio output relatively constant over a wide variation in the strength of received signals. This minimizes the variation of output due to fading of the received signal and prevents blasting and overloading when tuning through signals of greatly different strength while traversing a frequency band. In the AVC position the RF Meter circuit is operative for indication of tuning resonance and relative strength of received signals. The RF GAIN control is operative on AVC operation, when necessary to control exceptionally strong signals or to reduce noise, but the RF meter is less effective when the RF GAIN control is below maximum setting. In the MAN position the AVC potential is removed from the controlled tubes and the gain of the receiver is manually controlled by the RF GAIN control.

CW-Modulation Switch—The CW-MOD control in the CW position energizes the beat frequency oscillator and connects an additional timing capacitor to the AVC circuit to accommodate the AVC to slow keying. In the MOD position the beat frequency oscillator is inoperative and the conditions are established for either voice modulated or tone modulated signal reception.

Beat Frequency Oscillator—The BEAT OSC control varies the tuning of the 455 kc beat frequency oscillator over a range from zero beat to plus or minus 3 kilocycles.

BFO Injection—The BFO INJ control adjusts the cathode self bias of the beat frequency buffer amplifier, thereby determining the injection voltage to the detector tube.

Send-Receive—The SEND-REC control is a single pole, single throw toggle switch. In the SEND position it desensitizes the RF amplifier, gate, second mixer and 3.5 mc oscillator tubes during transmission periods.

Tuning Control and Dials—The TUNING control rotates the main tuning capacitor as well as the main and vernier tuning dials. The main dial has six frequency band scales, calibrated in megacycles, and an arbitrary outer scale. The vernier dial has an arbitrary 0 to 100 scale. The numeral under the upper or fixed pointer of the main dial indicates the number of complete revolutions that have been made by the vernier dial at any setting. Thus, if the pointer for the outer scale of the main dial indicates over the figure 4 and the vernier dial indicates 87.6, the reading to log for this setting is read, 487.6. This precise mechanical vernier system divides the rotation of the main dial over each frequency band into approximately 600 vernier divisions, with one-half division calibration points. Since it is easy to estimate one-tenth divisions on the vernier scale, this divides each frequency band into approximately 6000 readable settings. This permits extreme accuracy in the logging and resetting of stations.

Tuning Lock—The TUNING LOCK, located to the right of the TUNING control, provides a positive

lock for the tuning mechanism without affecting the frequency setting when it is desired to prevent accidental shifting of the tuning.

Band Change—Each revolution of the BAND CHANGE control turns the turret, containing the RF and HF Oscillator coil, trimmer and switch contact assemblies, from one frequency band to the next. The turret has no stops and may be turned in either direction desired. A positive detent mechanism assures correct location of the various bands. The BAND CHANGE control simultaneously operates the small MEGACYCLES band indicating dial, located at the center of the panel and aligns the dial frequency indicator with the proper scale of the main dial.

Crystal Controlled HF Oscillator—The XTALS control selects either variable high frequency oscillator operation or any one of the six crystal positions, for which similarly numbered crystal sockets are provided in the Crystal Control Unit. See Section III Installation. The DELTA FREQ control compensates for the small frequency tolerance to which the crystals are made.

Meter Switch—The METER switch is a double pole, double throw toggle switch with spring return to the RF position. See Section II Circuit Description, **Tuning Meter**.

Tuning Meter Controls—The METER ADJ RF control is used to adjust the resistance shunting the meter when the METER switch is in the normal, or RF position. It is adjusted to produce a reading of plus 20 db on the RF scale of the meter, with a 10 microvolt RF input signal and with the AVC-MAN switch in the AVC position. Depression of the METER switch to the AF position converts the meter circuit for indication of the AF power output level in db from 6 milliwatts. This switch is spring return to the RF position when released and **should not be depressed for the AF scale unless the audio output has been adjusted for low power output, by means of headphones or speaker. Failure to observe this precaution may result in damage to the meter.** The METER ADJ AF control is used to regulate the meter current when operating on the AF scale. This control is adjusted to obtain a 0 db reading on the AF scale of the meter and is made with the audio power output from the 600 ohm AUDIO OUTPUT terminals adjusted to 6 milliwatts, or 1.9 volts across a 600 ohm resistive load.

Preliminary to Operation—Turn the power switch "on" by turning the RF GAIN control clockwise and advance this control to 10. Note that the dial lamps light. Place the SEND-REC switch on REC and turn the BAND CHANGE control to the frequency band in which it is desired to operate. This should be done at least 15 minutes before using the receiver, in order to permit the tubes to warm up. Insert the headphones plug in the PHONES jack or use speaker as desired. See Installation, Section III.

MCW Reception—Turn the TUNING LOCK to its extreme counter-clockwise position and turn the SELECTIVITY switch to 3 kc. Put the CW-MOD

switch on MOD, the LIMITER switch to OFF, the AVC-MAN switch on AVC, the XTAL PHASING control at its center position and turn the XTALS switch to VFO. With the BAND CHANGE control in the proper position for the frequency band desired, as indicated by the MEGACYCLES dial, advance the AUDIO GAIN control until some noise is heard. Turn the TUNING control to indicate the desired frequency on the main dial and tune the signal for maximum response or indication on the RF Meter. At resonance the main dial reading should be within one-quarter of one percent of the signal frequency. Readjust the AUDIO GAIN control for the desired output level and as required to prevent overloading. Carefully tighten the TUNING LOCK by turning clockwise, if desired. The SELECTIVITY switch may be turned to the 8 kc or 13 kc position for improved high frequency response if the signal to noise ratio is sufficiently high. If the noise level is high, the SELECTIVITY switch should be turned to the bandwidth which provides the most intelligible reception and the LIMITER switch should be thrown "on." If the SELECTIVITY switch is used on either of the XTAL positions, the XTAL PHASING control may be adjusted to either side of its center position to attenuate an adjacent interfering signal. The RF GAIN control may be turned down somewhat to reduce noise, during stand-by periods in the transmission, when traversing the tuning range, or during deep fades of the signal. The RF Meter scale calibration is for maximum RF GAIN control operation and indicates only when the AVC-MAN switch is on AVC. When searching for very weak signals the CW-MOD switch may be thrown to CW and the BEAT OSC control set at 0. Locate and tune the signal to obtain zero beat and then throw the CW-MOD switch back to MOD.

The Crystal Frequency Control may be used for fixed frequency operation at any signal frequency for which crystals have been provided. See Section III, Installation. Turn the XTALS switch to the numeral corresponding to that on the panel chart for the de-

sired signal frequency. Set the main tuning dial to the signal frequency and adjust the DELTA C control to obtain zero beat with the CW-MOD switch on CW and the BEAT OSC control at 0. Throw the CW-MOD switch to MOD and adjust the TUNING Control for maximum RF Meter indication or for maximum response.

CW Reception — The preliminary procedure for CW reception is the same as for MCW reception above. Place the CW-MOD switch on CW and with the BEAT OSC control at 0, tune the desired signal for zero beat. Adjust the BEAT OSC control, in either direction, to obtain the audio pitch desired. The AVC-MAN switch may be used in the position which gives the best reception. Adjust the desired output level by the AUDIO GAIN control when on AVC and by the RF GAIN control when on MAN. The RF Meter does not operate on the MAN position. The SELECTIVITY switch may be used in the XTAL positions, as found desirable, to reduce noise or to provide rejection of an interfering signal. The XTAL PHASING control is adjusted for minimum interference from an adjacent, interfering signal. If interference of this kind persists, further discrimination between the desired and the undesired signals may be realized by slightly detuning the desired signal to the opposite side of resonance from that on which the undesired signal is located and readjusting the XTAL PHASING control and the BEAT OSC control for the desired signal. The Crystal Frequency Control may be used as described under MCW Reception above.

If reception is to be suspended and resumed at short time intervals, the power should be left "on" and for such operation the SEND-REC switch should be thrown to SEND between reception periods. This keeps the receiver warm and ready for instant use.

When operation of the receiver is completed, turn the power "off" by extreme counter-clockwise rotation of the RF GAIN control.

V

MAINTENANCE

General — This receiver is designed for continuous duty and should normally require little attention beyond the replacement of tubes. An occasional cleaning of the gear teeth in the gear train is recommended to prevent a heavy accumulation of dust which may cause calibration error and improper operation of the gears. This may be done with a small stiff bristle brush, turning the controls to obtain access to the different portions of the gears. No grease or oil should be used on the gears. Operation and maintenance of the receiver will be greatly facilitated if the contents of this instruction book are thoroughly digested.

Some sectionalizing of faults is possible, if the fault is not existent on all of the frequency bands. Non-operation of the three lower frequency bands, with normal operation on the three higher frequency bands, indicates that the fault is associated with the circuits

of tube V7. If only the three higher frequency bands are affected, the fault is associated with the circuits of V6 or V8. If only one single band is affected, refer to **HF Oscillator and RF Coil Assemblies** in this section.

Visual evidence of trouble is usually a burned or darkened resistor, which if found is likely caused by excessive current due to a short circuited capacitor or tube element at the load side of the resistor. In such a case, both the capacitor or tube and the resistor should be replaced as indicated. Refer to Figures 10 to 16 and Table 5 for location and values of components. If the checks on tubes, fuses and visual inspection fail to disclose the fault, the tube socket voltages and resistances should be measured and checked against the values given in Tables 1 and 2. Any appreciable departure beyond a normal variation

of approximately 15 percent from the values in these tables will generally indicate the component or circuit at fault. If the foregoing does not reveal the fault, then a stage by stage check of amplification should be made as shown in Table 4. Any great difference from the values of input shown in the table will indicate the stage at fault. If a tuned circuit component, such as an IF transformer, RF or HF oscillator coil assembly, is found defective and replaced only the replaced unit need be realigned. Follow the alignment procedure in Section VI, for the unit involved.

The IF Transformers, Crystal Filter, Beat Frequency Oscillator and the 3.5 mc Crystal Controlled Oscillator assemblies are each mounted on the chassis independently of their respective shields. The shield can assemblies are easily removed for inspection of these units, without disturbing the soldered connections. In replacing these shields, make sure that the grounding springs are in place on the inductance adjuster screws before the shield is installed.

Vacuum Tubes — Weak or defective vacuum tubes are the most common cause of decrease in sensitivity, faulty performance or failure of operation in a receiver. In case of such faults, first remove the tubes and check them in a tube tester of reliable design. If a tube tester is not available, substitution of a new tube for each tube type and position should be tried. See Figures 2 and 3. Such substitution is best made, one tube at a time in order that the faulty tube may be detected by the improvement or restoration of performance by the new tube.

Locating Faults — If the dial lamps do not light when the power switch is turned on, check for a blown line fuse, F1 and replace it at the rear of the receiver from the spare fuses. An open circuit in the line cord or plug may be checked by plugging a lamp first in the power source receptacle and then in the ac receptacle on the rear of the receiver. If the dial lamps light but there is no sound at all in the headphones or speaker, check for a blown minus B fuse, F2 and if blown, replace it with a spare fuse. **In replacing fuses, make sure that only a 1.6A Fusetron is inserted in the line fuse holder and that only a $\frac{3}{8}$ ampere fuse is inserted in the minus B fuse holder.** Should neither fuse be blown, nor replacement of the fuses restore operation, the receiver should be removed from its cabinet or rack and inspected for visual signs of trouble. The table model receiver is held in the cabinet by two screws through the cabinet bottom and by the four screws through the slotted holes at each side of the front panel. The rack model receiver is provided with bottom and top cover plates which should be removed for purposes of inspection and repair.

IF Transformers — If a fault is traced to one of the variable coupled IF Transformers, T4 or T5, check whether the fault exists on all positions of the selectivity switch S5, or only on one position of this switch. If the faulty operation occurs on only one switch position, check for continuity of the coupling coil associated with that position, check for imperfect soldered connections at the coil and switch terminals and check the switch contact involved. If faulty operation localized at one transformer exists on all positions

of the selectivity switch, make the continuity check on the plate coils, on the main grid coil and on the wiring associated with these coils. Transformers T4 and T5 and Crystal Filter T3 have additional inner shield assemblies that are held in place by the tension nuts on the adjusting screws. To remove these shields, hold the adjusting screws with a screw driver to prevent turning the screws and losing the alignment adjustment and loosen the tension nuts, using another small screw driver engaging one of the slots. When replacing these shields and tension nuts, employ the same method and tighten the tension nuts just enough to prevent the adjusting screws from working loose.

Beat Frequency Oscillator — To remove the beat frequency oscillator T6, if the receiver is equipped with the Crystal Frequency Control Unit T34, it will be necessary to set the crystal selector switch S2, on its number 3 position and loosen the four set screws in the rigid shaft coupling and the two set screws in the disc on the selector switch shaft. Slide the switch shaft forward through the coupling and disc. It may be necessary to remove burrs, caused by the set screws, from the switch shaft in order to slide the shaft through the disc. Now loosen the four set screws of the flexible coupling on the BFO shafts and slide the coupling forward on the BFO drive shaft in the front panel. Remove the BFO shaft bearing bracket by taking out the two screws holding it to the chassis. Unsolder the leads from the six terminals of the BFO unit at the underside of the chassis, **being careful to not overheat the wire of the shielded cable since this wire is insulated with polystyrene and is easily damaged by heat.** Note that if this cable wire is grounded to its shield, there will be no beat frequency voltage input to the buffer tube V12 even though the beat oscillator is functioning properly. Therefore, with the shielded lead disconnected from the lug of the BFO unit, check with a continuity or ohmmeter the connection of this wire to the buffer tube V12 and its freedom from the chassis. Carefully observe the wiring of the BFO unit for correct replacement. See T6 on Figure 14. Now remove the two screws holding the BFO shield can to the chassis and the two screws at the underside of the chassis and remove the BFO unit. When replacing the unit, follow the reverse procedure. Before tightening the two screws holding the unit to the chassis and the two screws holding the shaft bearing bracket, adjust the unit and shaft bracket to obtain alignment of the two shafts at the coupling. Make sure that the shield grounding spring is in place, with the bow of the spring downward against the tension nut, before replacing the shield can assembly.

Adjustment of BFO — With the AVC-MAN switch on AVC, and the SELECTIVITY control on the .2 kc position, tune in an unmodulated signal for maximum tuning meter reading. Set the CW-MOD switch to CW and with the BEAT OSC dial at 0, adjust the top screw of the BFO unit for zero beat. Turn the BEAT OSC dial to each 3 kc position and check the output beat frequency against a known audio frequency source such as a good audio oscillator. If the beat frequencies obtained at each 3 kc position is not within the range between 3 and 3.5 kc, loosen the set screws of the BFO shaft coupling and turn the

shaft of the BFO with respect to the drive shaft and repeat the above, resetting the 0 adjustment by the top screw of the BFO unit each time until the above range is realized. One set screw should be used just tightly enough to allow the drive shaft to operate the BFO shaft until the range is correct and then tighten both screws.

Crystal Switch Adjustment—If the mechanical drive of the crystal control switch has been disturbed, it should be adjusted as follows: Carefully slide the switch shaft through the disc and into the rigid coupling and being careful not to turn the switch, tighten the four set screws in the rigid coupling, with the knob indicator on the number 3 position as originally set under **Beat Frequency Oscillator**. Now set the crystal switch on the number 1 position and holding the disc in a counter-clockwise direction, so that the end of the slot in the disc is against the drive pin, lightly fasten the set screws of the disc. When this disc is properly adjusted on the shaft, with the switch in the number 1 position, the connecting bar between the two discs should not be under tension and should exhibit a slight amount of play when tried with the thumb and forefinger. When so adjusted, tighten the set screws.

Crystal Control Unit—If it has been determined that the Crystal Control Unit is defective, it will be necessary to remove the unit for repair or replacement. Refer to Figures 15 and 16 and unsolder the lead of capacitor C60 from switch S3 on the gear plate. Unsolder the black, black-white, blue-red and red-white leads of the crystal control unit from terminal strip E13 underneath the chassis and unsolder the red lead of the unit from filter capacitor C161. Remove the XTALS switch shaft, as described under **Beat Frequency Oscillator**. Loosen set screws and remove the delta C control knob. Remove the nut and lockwasher at the top of the bracket post adjacent to the power transformer and remove the bracket over the filter chokes. The front end of this bracket is slotted and engages a groove in a mounting post of the crystal control unit. Remove the four screws that secure the filter assembly panel to the mounting posts at each corner of this panel and move the filter assembly sufficiently to permit removal of the four screws holding the crystal control unit to the chassis. When these screws are removed, the unit may be taken from the receiver. In removing the unit and in subsequently handling it, be careful to avoid any strain on the delta C shaft, or the delta C capacitor may be damaged. Remove the four screws holding each of three sides of the cover and spring the two top ends of the cover enough to make the flanges clear the top of the box. Hold these flanges apart to prevent their edges from damaging the rf chokes in the unit while sliding the cover off the crystal unit box. When the unit is to be replaced, follow the reverse of the above procedure. Follow the procedure under **Crystal Switch Adjustment** to properly reinstall the switch mechanism.

HF Oscillator and RF Coil Assemblies—If faulty operation occurs in only one frequency band of the receiver, the trouble should be found in one of the four coil assemblies for that band in the tuning unit

turret. For example: Coil assemblies T13, 19, 25 and 31 should be examined if band 7.4 to 14.8 mc only, does not perform normally. To remove these coil assemblies stand the receiver on its right or left side and remove the bottom cover plate from the tuning unit. Turn the band change control to place the band in question in its normal operating position and then turn the band change control two and one-half revolutions counter-clockwise. This will place the band coil assemblies parallel and at the bottom of the tuning unit. Now remove the two springs holding one coil assembly in the turret and carefully remove it by sliding it towards you and off the tongues of the shields. It is best to remove only one coil assembly at a time and inspect it for defects or substitute a replacement assembly if available. **Caution: Make sure that the coil base is firmly seated and secured by its retaining springs before going to the next assembly or turning the band change control. Failure to do this may damage the switch spring contacts beyond repair.** Repeat this procedure until the faulty assembly is found. In checking these assemblies, first check for continuity of the coils, particularly the small primary coils as in the RF Input assemblies, where they are liable to damage if the receiver is operated in the presence of very strong transmitter signals. In replacing these coil assemblies be careful that the end of the assembly nearest the coil is toward the front of the receiver.

Mixer Plate Coil Assembly—Trouble in the Mixer Plate Coil Assembly T1, is indicated if the input required at pin 7 of V5 is found to be greatly different than the values shown in Table 4, and the gain from pin 7 of V6 is normal. To obtain access to the components of the mixer plate coil assemblies it is necessary to remove the crystal control unit and the filter assembly as described under **Crystal Control Unit**. The cover plate and shield of T1 may then be removed for replacement of a defective component. If the entire assembly is to be replaced, it will be necessary to unsolder all of the leads at both the bottom and top terminal boards of the unit. Refer to Figure 15 for components and wiring of T1.

RF Tube Platform—If the receiver fails to perform normally on any of the six frequency bands and the previous tests indicate that performance of the IF and audio frequency amplifiers is normal, including the gain check in accordance with Table 4 for the input to pin 7 of V5, the fault is indicated to be in the RF Tube Platform or in the main tuning capacitor. Before removing the RF Tube Platform, it is advisable to remove the top shield cover and inspect the main tuning capacitor connections. Refer to Figures 8 and 15. Observe that the tuning capacitor is operating properly when the tuning control is rotated. Using a miniature tube adapter, see Section VI alignment, apply a modulated rf test signal successively to pin 1 of V1 and V2 and to pin 7 of V5. For each of these positions of the adapter and signal, tune through the proper dial setting for the signal frequency used. Gain of the order of 5 or 6 should be indicated for each stage and loss of signal will indicate the section to be investigated for the fault. No signal output, when the input signal is applied to pin 7 of V5, will indicate trouble in the HF oscillator section of the unit. With the

covers removed from the tuning capacitor and T1, refer to Figure 15 and unsolder the blue, white-black, red-white, red-green, yellow-black and blue-red leads that come from the tube platform at the top of T1. Unsolder the leads from the tuning capacitor rotors, stators and ground straps at each section. Unsolder the lead from the tube platform at S3. Turn the Band Change control one-half turn from any band position in order to have the band switch contacts disengaged and leave the band switch in this position until the RF tube platform is replaced, otherwise irreparable damage to the switch contacts will occur. Remove the four screws at the corners of the top of the platform and the four screws at the side flange and carefully remove the platform. In handling be careful to prevent damage to the switch contacts of this assembly. When the unit is ready to be replaced, follow the reverse of the above procedure.

Main Tuning Capacitor— If it is necessary to replace the main tuning capacitor, the procedure is as follows: Remove the top cover and unsolder the leads of the capacitor as described under **RF tube Platform**. Bring the capacitor to full mesh by means of the tuning control. Carefully remove the spring and drive link at the front of the capacitor. Remove the single screw that secures the capacitor frame front plate to the gear plate, looping a piece of small wire around the spacing washer between the capacitor and gear plate. The front capacitor plate is located and held in position by two dowel pins and will not move when the front screw is taken out. Now hold the capacitor by its frame with one hand and remove the rear supporting screw and spacer. The capacitor may now be moved to the rear, to disengage the dowel pins, and lifted from the receiver. Follow the above procedure in reverse when replacing the capacitor.

TUBE SOCKET VOLTAGES—TABLE 1

Voltage to chassis. Measurements made with Weston Model 663 Volt-Ohmmeter, except those indicated by asterisk were made with Measurements Corp. Model 62 VTVM. The 500 volt scale was used for all voltages above 10 volts and the 10 volt scale for voltages below 10 volts. Line voltage 117, no signal input. Audio Gain control at minimum and CW-MOD switch on "CW" AVC tap normal.

SOCKET PIN NUMBERS										MODE OF OPERATION
TUBE	1	2	3	4	5	6	7	8	9	
V-1	*-1	—	*6.3ac	—	200	95	—	—	—	RF Gain max.
V-1	*-41	—	*6.3ac	—	260	245	—	—	—	RF Gain min.
V-2	*-1	—	*6.3ac	—	210	95	—	—	—	RF Gain max.
V-2	*-41	—	*6.3ac	—	260	245	—	—	—	RF Gain min.
V-3	—	—	—	—	—	0	*6.3ac	265	—	RF Gain max.—VFO operation
V-3	—	—	—	—	—	150	*6.3ac	265	—	RF Gain max.—Crystal Freq. Control
V-3	—	—	—	—	—	0	*6.3ac	290	—	RF Gain min.—VFO operation
V-3	—	—	—	—	—	150	*6.3ac	290	—	RF Gain min.—Crystal Freq. Control
V-4	130	—	*6.3ac	—	130	—	—	—	—	RF Gain max. or min.
V-5	—	1.2	*6.3ac	—	140	110	—	—	—	RF Gain max. or min.
V-6	—	—	*6.3ac	—	225	—	*-1	—	—	RF Gain max.—Freqs. below 7.4mc
V-6	—	—	*6.3ac	—	260	—	*-55	—	—	RF Gain min.—Freqs. below 7.4mc
V-6	—	—	*6.3ac	—	225	80	*-1	—	—	RF Gain max.—Freqs. above 7.4mc
V-6	—	—	*6.3ac	—	260	75	*-55	—	—	RF Gain min.—Freqs. above 7.4mc
V-7	*-1	—	*6.3ac	—	215	125	3.4	—	—	RF Gain max.—Freqs. below 7.4mc
V-7	*-54	—	*6.3ac	—	265	245	.4	—	—	RF Gain min.—Freqs. below 7.4mc
V-7	*-1	—	*6.3ac	—	215	0	0	—	—	RF Gain max.—Freqs. above 7.4mc
V-7	*-54	—	*6.3ac	—	265	0	0	—	—	RF Gain min.—Freqs. above 7.4mc
V-8	0	—	*6.3ac	—	0	—	—	—	—	Frequencies below 7.4mc
V-8	30	—	*6.3ac	—	30	—	—	—	—	Frequencies above 7.4mc
V-9	*-1	—	*6.3ac	—	205	90	—	—	—	RF Gain max.
V-9	*-54	—	*6.3ac	—	260	150	—	—	—	RF Gain min.
V-10	*-1	—	*6.3ac	—	205	90	—	—	—	RF Gain max.
V-10	*-54	—	*6.3ac	—	260	150	—	—	—	RF Gain min.
V-11	*-7.8	—	*6.3ac	—	210	140	—	—	—	RF Gain max.
V-11	*-7.8	—	*6.3ac	—	235	140	—	—	—	RF Gain min.
V-12	—	—	*6.3ac	—	210	40	—	—	—	RF Gain max.—BFO Injection max.
V-12	—	—	*6.3ac	—	240	45	—	—	—	RF Gain min.—BFO Injection max.
V-13	25	—	*6.3ac	—	25	—	—	—	—	RF Gain max. or min.
V-14	—	—	*6.3ac	—	*22	—	—	—	—	RF Gain max. or min.
V-15	—	—	*6.3ac	—	—	—	—	—	—	RF Gain max. or min.
V-16	50	—	1.5	—	—	210	—	6.4	*6.3ac	RF Gain max.
V-16	57	—	1.6	—	—	240	—	7.4	*6.3ac	RF Gain min.
V-17	—	—	260	228	—	—	*6.3ac	12	—	RF Gain max.
V-17	—	—	280	265	—	—	*6.3ac	13	—	RF Gain min.
V-18	150	—	—	—	150	—	—	—	—	RF Gain max. or min.
V-19	—	300	—	—	—	—	—	300	—	RF Gain max.—*5 V ac Pin 2 to Pin 8
V-19	—	320	—	—	—	—	—	320	—	RF Gain min.—*5 V ac Pin 2 to Pin 8
V-20	—	*-96	*6.3ac	—	—	—	*-96	—	—	RF Gain max.
V-20	—	*-97	*6.3ac	—	—	—	*-97	—	—	RF Gain min.

TUBE SOCKET TERMINAL RESISTANCE—TABLE 2

Resistance to chassis. Measurements made with Weston Model 663 Volt-Ohmmeter.

Tube removed from socket under measurement. Audio Gain Control at maximum, RF Gain Control at minimum. Limiter Switch "OFF". CW-MOD Switch on "CW". AVC-MAN Switch on "AVC". AVC tap normal.

Socket Pin No.	1	2	3	4	5	6	7	8	9	MODE OF OPERATION
Tube Socket										
V-1	1.8M	0	—	0	16.7K	50K	0	—	—	
V-2	1.8M	0	—	0	16.7K	50K	0	—	—	
V-3	0	—	0	47K	0	17.5K	—	15.6K	—	Crystal Freq. control pos. 1-6
V-4	Inf.	Inf.	—	0	Inf.	47K	0	—	—	Crystal Freq. control pos. 1-6
V-4	19K	Inf.	—	0	Inf.	47K	0	—	—	VFO Operation
V-5	47K	150	—	0	19K	22K	26K	—	—	Freq. Band 1.35-3.45mc
V-6	22K	0	—	0	17.4K	Inf.	1.1M	—	—	Freq. Bands below 7.4mc
V-6	22K	0	—	0	17.4K	37.4K	1.1M	—	—	Freq. Bands above 7.4mc
V-7	980K	0	—	0	17.4K	Inf.	390	—	—	Freq. Bands above 7.4mc
V-7	980K	0	—	0	17.4K	48K	390	—	—	Freq. Bands below 7.4mc
V-8	—	—	—	0	Inf.	22K	0	—	—	Freq. Bands below 7.4mc
V-8	—	—	—	0	117K	22K	0	—	—	Freq. Bands above 7.4mc
V-9	1.1M	0	—	0	17.5K	9.5K	0	—	—	
V-10	1.1M	0	—	0	17.5K	9.5K	0	—	—	
V-11	93K	0	—	0	17.5K	19K	0	—	—	
V-12	1.5	0	—	0	17.5K	115K	*	—	—	*0 to 1K (BFO Injection control)
V-13	—	—	—	0	162K	100K	0	—	—	
V-14	0	816K	—	0	15.6K	0	196K	—	—	
V-15	69 K	Inf.	—	0	Inf.	0	196K	—	—	
V-16	125K	500K	1K	0	0	17.4K	470K	680	—	
V-17	0	0	15.6K	15.2K	470K	Inf.	—	360	—	
V-18	118K	—	—	—	20K	—	0	—	—	
V-19	—	15.8K	0	42	—	40	—	15.8K	—	
V-20	49K	65K	—	0	49K	0	65K	—	—	

VI ALIGNMENT

The alignment of a modern communications receiver requires precision instruments and a thorough knowledge of the circuits involved. This receiver, being a double super-heterodyne, the alignment procedure is even more involved than is usual.

Under normal service the receiver will stay in alignment for extremely long periods of time, consequently

realignment should not be attempted unless all other possible causes of a particular trouble have been eliminated. When it has been determined that any realignment should be attempted, a great deal of caution should be exercised in making the adjustments, as any required readjustment should not entail more than a slight angular motion of the adjusting screw.

ALIGNMENT OF THE IF STAGES

The low frequency IF should be aligned first. The recommended method for aligning the low frequency IF involves the use of a sweep frequency signal generator and an oscilloscope. Since these instruments are not available at the average service station the alternate method using an amplitude modulated signal generator and an output meter will be described first. The additional information required for the visual alignment method will be covered in a later paragraph.

The signal generator should be coupled to the grid of the mixer tube V5 through a capacitance of approximately .01 mfd. A miniature tube adapter will be required to make the mixer grid connection available. A suitable adapter, A/N No. CV-49519, is available as Part No. 977 from Alden Manufacturing Co., 117 N. Main Street, Brockton, Mass. An output meter should be connected across the output terminals of the receiver or the speaker voice coil. The receiver controls should now be set as follows:

Control	Position
Selectivity	— See text
Send — Receive	— Receive
CW — Mod	— Mod
Phasing	— Arrow
AVC — Man	— Man
Audio Gain	— Set for approx. 20 volts
RF Gain	— See text
Band Switch	— 1.35 — 3.45 mc
Dial	— 2.5 mc

The signal generator should be modulated 30 percent at 400 cycles. Turn the selectivity switch to the 3 kc position and advance the RF Gain control to maximum. Set the signal generator frequency to 455 kc and adjust its output until some deflection is noted on the output meter. Refer to figure 3 for the location of the various alignment adjustments. Adjust L42, L41, L39, L38, L36 and L32 for maximum output, reducing the signal generator output and the RF Gain control as required to prevent overload or excessive output. Now turn the selectivity switch to the narrow-

est position, .2 kc, and adjust the signal generator frequency for the maximum output. This establishes the correct signal frequency by the 455 kc crystal for the IF amplifier and the frequency of the signal generator should not be disturbed for the remainder of the low frequency IF alignment, unless it should be to recheck this establishment of crystal frequency to make sure that the signal generator frequency has not drifted during the alignment. The selectivity switch is now turned to the 3 kc position and L42, L41, L39, L38, L36 and L32 are again adjusted for maximum output. Now turn the selectivity switch to the 1.3 kc position and adjust L37 for maximum output. Before changing this set-up the BFO should be turned on by throwing the CW-Mod switch to CW and checked for zero beat with the BFO knob dial at its zero reading. If necessary L44 should be adjusted for zero output. This check and adjustment of the BFO should be done with the signal generator carrier unmodulated.

The procedure for the visual method of aligning the low frequency IF should be the same as the above except that the adjustments are made for both maximum amplitude and coincidence of the oscilloscope images. The oscilloscope vertical input should be connected across the diode detector load resistance, from the junction of R64 and R65 to chassis.

The high frequency IF should be aligned next. Set the band switch to the 7.4 — 14.8 mc band. The selectivity switch should be in the 3 kc position. Adjust the signal generator frequency to 3.955 mc and adjust L31, L33 and L34 for maximum output.

The 3.5 mc crystal used in the second conversion oscillator circuit is held to a very close frequency tolerance and may be used as a frequency standard at multiples of 3.5 mc from 10.5 mc upwards. In order to do this, in view of the complete shielding against radiation from this oscillator, it will be necessary to temporarily connect a two foot length of insulated wire to the antenna terminal and dress the free end of this lead around the tube shield on the 3.5 mc oscillator tube V8. This test lead should, of course, be removed except while in use as a frequency standard.

ALIGNMENT OF THE RF AMPLIFIER & HF OSCILLATOR

To adequately align the RF Amplifier and HF Oscillator an accurately calibrated signal generator and an output meter are required. The frequencies required are shown in table 3. The location of the adjustments is shown in Figure 3. The use of Table 3 and Figure 3 should be made in following this part of the alignment which will now be described for one frequency band. The same procedure should then be followed for the other frequency bands.

To align the .54-1.35 mc band the signal generator is coupled to the antenna input terminal through a 100 ohm carbon resistor. The generator should be modulated 30 percent at 400 cycles and the output meter connected across the receiver output terminals. The receiver controls should be set as follows:

Control	Position
Selectivity	— 3kc
Send-Receive	— Receive
CW — Mod	— Mod
AVC — Man	— See Text
Audio Gain	— Set for approx. 20 volts
RF Gain	— See text
Band Switch	— set for band to be aligned
Limiter	— off

Set the receiver and signal generator dials to .56 mc. The RF Gain control should be set at maximum and the AVC — Man switch set on AVC. The HF Osc. L adjustment shown in Figure 3, should now be set for maximum output. Then the Ant., 1st RF and 2nd RF L adjustments should be set for maximum output. The receiver and signal generator dials are now set to 1.3 mc and the C adjustments, shown in Figure 3, should be adjusted for maximum output in the same order, beginning with the Osc C adjustment and then making the C adjustments for the Ant, 1st RF and 2nd RF. This procedure should be carefully repeated until no increase in output can be realized. The AVC — Man switch should then be set to Man and the signal generator should be set for approximately 3 micro volts. The L and C adjustments should now be checked for maximum output, adjusting the RF Gain control as found necessary to maintain the output at approximately 20 volts.

Following the frequencies, shown in Table 3, align the remaining bands using the same procedure as above.

TABLE No. 3

RF AND HF OSCILLATOR ALIGNMENT FREQUENCIES AND ADJUSTMENT DESIGNATIONS

FREQ. BAND IN MC	.54—1.35	1.35—3.45	3.45—7.4	7.4—14.8	14.8—29.7	29.7—54.0
RF & HF OSC ADJUST L AT.	.56	1.4	3.75	7.5	15.0	30.0
RF & HF OSC ADJUST C AT.	1.3	3.4	7.15	14.5	29.0	52.0

TABLE No. 4

APPROXIMATE SIGNAL INPUT AT IF & AF STAGES FOR 20 VOLTS OUTPUT

Output measured across a 600 ohm resistive load at output terminals of receiver. RF signals modulated 30 percent at 400 cycles. Signals applied to tube grids through a .01 mfd capacitor. Selectivity switch at 3 kc AVC — MAN switch on MAN. CW — MOD switch on MOD, RF Gain and Audio Gain at maximum.

BAND SWITCH	FREQUENCY	INPUT TO	APPROX. INPUT
Any	Audio 400 cycles	Pin 5, V17	5.5 volts
Any	Audio 400 cycles	Pin 2, V16B	.5 volts
1.35—3.45 mc	Mod RF 455 kc	Pin 1, V11	.6 volts
1.35—3.45 mc	Mod RF 455 kc	Pin 1, V10	15000 microvolts
1.35—3.45 mc	Mod RF 455 kc	Pin 1, V9	300 microvolts
1.35—3.45 mc	Mod RF 455 kc	Pin 1, V7	75 microvolts
1.35—3.45 mc	Mod RF 455 kc	Pin 7, V5	90 microvolts
7.40—14.8 mc	Mod RF 3.955 mc	Pin 7, V5	70 microvolts
7.40—14.8 mc	Mod RF 3.955 mc	Pin 7, V6	100 microvolts

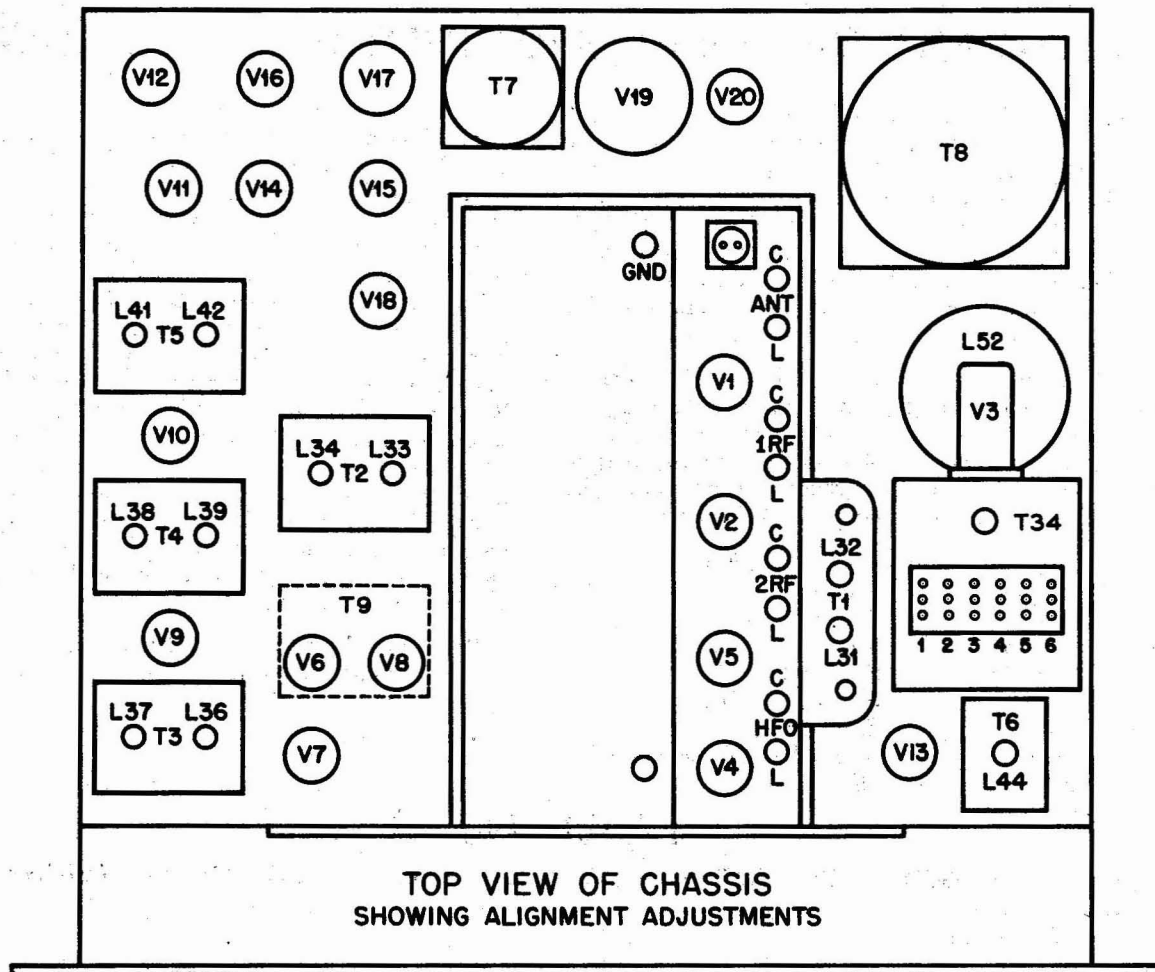

FIG. 3

•AUDIO AND OVERALL FIDELITY CURVES•

- CURVE - Audio frequency amplifier. Input to Pin 2, V16B.
- - - - CURVE - Overall fidelity at 2.5 mc. Modulation 30 percent.
Selectivity switch in 13 kc position.
RF Gain set for 20 volts output at 400 cycles.
Output measured across a 600 ohm resistive load.
Audio gain control at maximum for both curves.

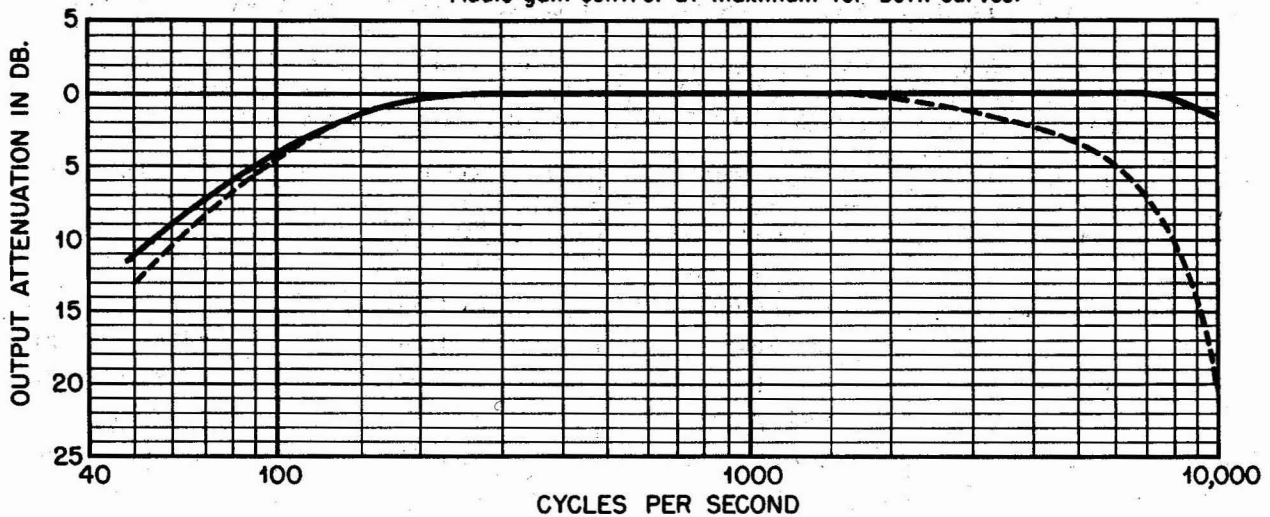

FIG. 4

• SELECTIVITY CURVES
Overall at 2 Megacycles •

NUMBERS DENOTE SELECTIVITY SWITCH POSITIONS
1,2 AND 3 NON CRYSTAL — 4,5 AND 6 CRYSTAL

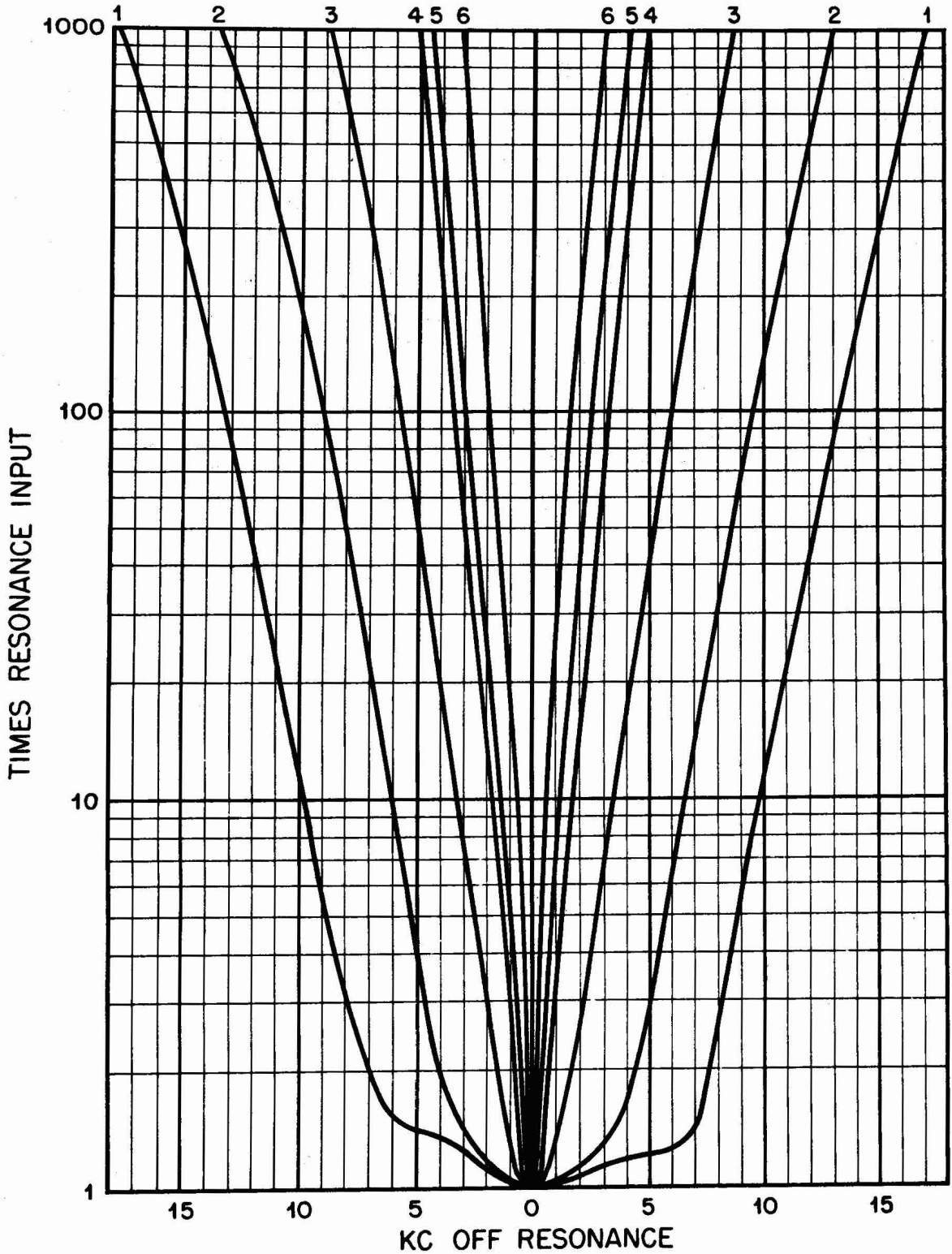

FIG. 5

VII

CONVERSION OF TABLE MODEL RECEIVER FOR RACK MOUNTING

The SP-600 Receiver is designed for either table cabinet or rack mounting. When table models are ordered, the receiver is not supplied with a bottom cover plate since the cabinet serves this purpose. When rack models are ordered the receiver is supplied with a bottom plate and a top cover plate assembly to prevent dirt or loose hardware from falling into the gear train of the receiver.

A cover plate kit is provided, on separate order, for conversion to rack mounting where table models have been ordered and where the covers are desired. The kit number, 31478-G1, should be specified when ordering for this conversion.

The following instructions should be followed when installing the cover kit; To install the bottom cover plate, remove the two rear corner nut plate brackets by removing the three screws at the lower rear ends of the large side mounting brackets and replace these

two nut plate brackets with the two slightly shorter ones from the kit, using the same screws. Remove the nut and lockwasher from the screw, nearest the bottom edge of the chassis, holding capacitor C151 (see bottom of chassis photograph). Install the short angle bracket, from the kit, using the same screw from which the nut and washer were removed, with the tapped (smaller end) of the bracket replacing the nut. The bottom cover plate is now installed using the five 10-32 screws from the kit and the two 10-32 screws that previously held the bottom of the receiver to the cabinet. To install the top cover plate assembly, place the cover with the angles facing downward toward the chassis and with pressure applied at the rear of the plate, to slightly compress the rubber channel against the rear of the front panel, secure the assembly in place with the four 6-32 screws from the kit, engaging them in the tapped holes in the brackets through the clearance holes in the side mounting brackets.

TABLE No. 5 PARTS LIST

Symbol Designations	DESCRIPTION	Hammarlund Part No.	Symbol Designations	DESCRIPTION	Hammarlund Part No.
C1A to H	Capacitor, variable, 8 sections	34001-G1	C115-116	Same as C3	
C3	Capacitor, .01 mfd	23034-8	C117	Same as C69	
C5	Same as C3		C118	Same as C98	
C6	Capacitor, 20 mmf	23003-41C	C119	Capacitor, 300 mmf	23003-105C
C8	Capacitor, 2400 mmf	23011-40C	C120	Capacitor, 1300 mmf	23011-61C
C9	Capacitor, 33 mmf	23003-45C	C121-122	Same as C3	
C11	Capacitor, 1500 mmf	23011-62C	C123	Same as C98	
C12	Capacitor, 7 mmf	23061-168F	C124	Same as C69	
C14	Capacitor, 1000 mmf	23011-58C	C125	Same as C119	
C15	Capacitor, 15 mmf	23061-155J	C126	Same as C120	
C17	Same as C11		C127	Same as C3	
C18	Capacitor, 100 mmf	23003-94C	C128	Capacitor, 10 mfd, 100V HS Can, Electrolytic.	15462-1
C19 to 24	Same as C3		C129A, B	Capacitor, 2 x .05 mfd, HS Can, Paper	15461-1
C25	Same as C18		C130	Capacitor, 27 mmf	23023-71UJ
C27	Same as C3		C131	Capacitor, 430 mmf	23003-109C
C29	Same as C3		C132	Same as C8	
C30	Same as C6		C133	Same as C131	
C32	Same as C8		C134	Same as C39	
C33	Same as C9		C135	Same as C3	
C35	Same as C11		C136	Same as C98	
C37	Same as C18		C137	Capacitor, .25 mfd, 200V	23911-79E
C39	Capacitor, 51 mmf	23003-87C	C138-139	Same as C92	
C40 to 44	Same as C3		C140	Same as C131	
C47	Same as C3		C141-142	Capacitor, 100 mmf	23024-24SL
C49	Same as C3		C143	Capacitor, 5100 mmf	23015-16A
C50	Same as C6		C144	Capacitor, .05 mfd	23911-77E
C52	Same as C8		C145	Same as C15	
C53	Same as C9		C146	Same as C98	
C55	Same as C11		C147	Same as C143	
C57	Same as C18		C148	Same as C98	
C59	Same as C39		C149	Same as C143	
C60	Capacitor, 12 mmf	23023-65UJ	C150	Capacitor, 2500 mmf, 800V	23070-40
C61	Same as C3		C151	Same as C128	
C62	Capacitor, 2200 mmf	23011-17C	C152	Capacitor, .01 mfd 500V	23072-11
C63	Capacitor, 39 mmf	23003-47C	C153 to 155	Same as C3	
C64	Same as C3		C156-157	Same as C98	
C65	Capacitor, variable	11726-G109	C158 to 160	Same as C128	
C66	Same as C3		C161A, B, C	Capacitor, 3 x 20 mfd, 450V, HS Can, Electrolytic	15463-1
C67	Capacitor, 85 mmf	23071-59	C162	Same as C98	
C68	Same as C3		C163	Capacitor, .25 mfd, 600V	23915-1
C69	Capacitor, 220 mmf	23003-102C	C164	Same as C131	
C70 to 74	Same as C3		C165-166	Same as C3	
C75	Same as C18		C167	Same as C98	
C77	Capacitor, 3300 mmf	23011-69C	C168-169	Same as C152	
C78	Capacitor, 404 mmf	23071-67	E2	4 Screw Terminal, Audio Output	31141-1
C79	Capacitor, 5 mmf	23023-8UJ	E3	4 Screw Terminal, Diode and AVC	31480-1
C80	Same as C79		E4-5	1 Solder Terminal strip (left)	16650-9
C82	Capacitor, 810 mmf	23072-53	E6	1 Solder Terminal strip (right)	16650-11
C83	Capacitor, 10 mmf	23003-2B	E7	2 Solder Terminal strip.	16650-12
C85	Capacitor, 1200 mmf	23011-60C	E8	Same as E4	
C87	Capacitor, 120 mmf	23071-50	E9 to 12	Same as E6	
C88	Same as C60		E13	10 Solder Terminal Board	33928-G1
C89	Capacitor, 190 mmf	23071-64	E14	6 Solder Terminal strip.	16650-10
C91	Same as C18		E15-16	8 Solder Terminal strip.	31163-G1
C92	Capacitor, 51 mmf	23023-45UJ	E17	15 Solder Terminal strip	31162-G1
C93	Capacitor, 379 mmf	23071-63	E18	3 Solder Terminal strip (meter)	31454-G1
C95	Same as C39		F1	Fuse, 1.6A Fusetron	15893-1
C96	Capacitor, 610 mmf	23072-52	F2	Fuse, 3/8 Amp	15928-13
C97	Capacitor, 65 mmf	23071-58	I1 to 4	Dial Lamp, No. 47 Mazda	16004-1
C98	Capacitor, .01 mfd	23034-8	J1	Antenna input socket, UG-103/U	15959-1
C99	Same as C39				
C102 to 104	Same as C98				
C105	Same as C3				
C106	Same as C98				
C107	Same as C69				
C108-109	Same as C98				
C110	Same as C18				
C111	Capacitor, variable	11776-G1			
C112-113	Same as C18				
C114	Capacitor, 270 mmf	23003-104C			

PARTS LIST (Continued)

Symbol Designations	DESCRIPTION	Hammarlund Part No.	Symbol Designations	DESCRIPTION	Hammarlund Part No.
J2	IF Output Socket, SO-239	16111-1	R33	Resistor, 1500 ohms 1/2 watt	19309-53BF
J3	Phone Jack, JK-34-A ...	5066-1	R35	Resistor, 100K ohms 1/2 watt	19309-97BF
J5	Power receptacle	35013-1	R36	Resistor, 22K ohms 1/2 watt	19309-178BF
L7	RF Choke, 192 microhenries	15612-G1	R37	Same as R31	
L14	Same as L7		R38	Same as R35	
L21	RF Choke, 1 millihenry.	15617-G1	R39	Same as R3	
L22	RF Choke, 10 millihenries	15618-1	R40	Resistor, 20K ohms 1 watt	19310-179BF
L23	RF Choke, 25 millihenries	15619-1	R41	Same as R31	
L24	RF Choke, 2.5 millihenrys	15627-1	R42	Resistor, 10 ohms 1/2 watt	19309-1BF
L35	Same as L7		R43	Same as R35	
L46	RF Choke, 12 microhenries	15615-2	R44	Same as R2	
L47	RF Choke, 3.0 millihenries	15616-G1	R45	Resistor, 240 ohms 1/2 watt	19309-201BF
L48	RF Choke, 2 ohms dc ..	15611-1	R46	Resistor, 1100 ohms 1/2 watt	19309-208BF
L49-50	RF Choke, 2.7 ohms dc.	15613-1	R47	Resistor, 18K ohms 1/2 watt	19309-79BF
L51	1st Filter Choke, 8.5 Hy, 170 ohms dc	31030-2	R48	Resistor, 1 megohm 1/2 watt	19309-121BF
L52	2nd Filter Choke, 20 Hy, 440 ohms dc	31031-2	R49	Same as R31	
L53	IF Output transformer.	31488-1	R50	Same as R42	
M1	Tuning Meter	4903-2	R51	Same as R35	
P1	Power plug and cord ..	6143-1	R52	Same as R2	
P2	Antenna Input Plug, UG-102/U	16016-1	R53	Same as R2	
P3	Antenna Adapter Connector UG-104/U.	15987-1	R54	Same as R31	
P4	Cable Connector Plug PL-259 (for J2)	16071-1	R55	Same as R42	
R1	Resistor, 510K ohms 1/3 watt	19317-76BF	R56	Same as R35	
R2	Resistor, 10K ohms 1/2 watt	19309-278BF	R57	Same as R2	
R3	Resistor, 33K ohms 1/2 watt	19309-282BF	R58	Same as R31	
R4	Resistor, 1000 ohms 1/2 watt	19309-49BF	R59	Resistor, 2200 ohms 1 watt	19310-57BF
R5	Resistor, 510 ohms 1/2 watt	19309-170BF	R60-61	Same as R48	
R6	Same as R4		R62	Same as R35	
R7-8	Resistor, 51 ohms 1/2 watt	19309-193BF	R63	Resistor, 27K ohms 1/2 watt	19309-83BF
R9	Resistor, 24 ohms 1/2 watt	19309-189BF	R64	Same as R22	
R10-11	Resistor, 22 ohms 1/2 watt	19309-9BF	R65	Same as R36	
R12	Same as R2		R66	Same as R47	
R13	Same as R1		R67-68	Same as R35	
R14	Same as R3		R69	Resistor, variable 3300 ohms	15366-1
R15	Same as R5		R70	Same as R2	
R16	Same as R4		R72	Resistor, 7500 ohms 20 watt	19397-41
R17-18	Same as R7		R73	Resistor, 10K ohms 20 watt	19397-43
R19	Same as R9		R74	Resistor, variable 1000 ohms	15363-1
R20-21	Same as R10		R75-76	Same as R35	
R22-23	Resistor, 47K ohms 1/2 watt	19309-89BF	R77	Same as R22	
R24-25	Resistor, 180 ohms 1/2 watt	19309-31BF	R78	Resistor, 470K ohms 1/2 watt	19309-113BF
R26	Same as R1		R79	Resistor, 680 ohms 1/2 watt	19309-45BF
R27	Resistor, 150 ohms 1/2 watt	19309-259BF	R80	Same as R31	
R28	Resistor, 6800 ohms 1/2 watt	19309-69BF	R81	Same as R35	
R29-30	Same as R4		R82	Same as R2	
R31	Resistor, 2200 ohms 1/2 watt	19309-57BF	R83	Same as R4	
R32	Same as R5		R84	Resistor, variable 500K ohms	15342-11
			R85	Resistor, 2500 ohms 10 watts	19396-1
			R86	Resistor, 82K ohms 1/2 watt	19309-287BF
			R87-88	Resistor, 120K ohms 1/2 watt	19309-181BF
			R89	Same as R86	

PARTS LIST (Continued)

Symbol Designations	DESCRIPTION	Hammarlund Part No.	Symbol Designations	DESCRIPTION	Hammarlund Part No.
R90 to 92 R93	Same as R2 Resistor, variable 50K ohms, includes switch S10	15342-21	T11	RF Input assembly, includes C4, 5, L2 and switch contacts for S1A	31390-G1
R94	Same as R46		T12	RF Input assembly, includes C6, 7, 8, L3 and switch contacts for S1A	31393-G1
R95	Same as R86		T13	RF Input assembly, includes C9, 10, 11, L4 and switch contacts for S1A	31396-G1
R96	Same as R36		T14	RF Input assembly, includes C12, 13, 14, L5 and switch contacts for S1A	31399-G1
R97	Resistor, 3.3 megohms 1/2 watt	19309-133BF	T15	RF Input assembly, includes C15, 16, 17, L6 and switch contacts for S1A	31405-G1
R98	Same as R78		T16	RF Transformer assembly, includes C26, 27, L8, R7, 103 and switch contacts for S1B	31386-G1
R99	Resistor, 360 ohms 1 watt	19310-211BF	T17	RF Transformer assembly, includes C28, 29, L9, R8, 105 and switch contacts for S1B	31389-G1
R100	Same as R35		T18	RF Transformer assembly, includes C30, 31, 32, L10, R9, 107 and switch contacts for S1B	31392-G1
R101	Resistor, variable 25K ohms	15342-4	T19	RF Transformer assembly, includes C33, 34, 35, L11, R10, 109 and switch contacts for S1B	31395-G1
R103 to 110	Same as R63		T20	RF Transformer assembly, includes C36, 37, L12 and switch contacts for S1B	31398-G1
R111	Same as R35		T21	RF Transformer assembly, includes C38, 39, L13 and switch contacts for S1B	31404-G1
R112	Resistor, 390 ohms 1/2 watt	19309-162BF	T22	Same as T16 includes C46, 47, L15, R17, 104 and switch contacts for S1C	31386-G1
R113	Resistor, 330K ohms 1/2 watt	19309-241BF	T23	Same as T17, includes C48, 49, L16, R18, 106 and switch contacts for S1C	31389-G1
R114	Same as R4		T24	Same as T18, includes C50, 51, 52, L17, R19, 108 and switch contacts for S1C	31392-G1
R115-116	Resistor, 1.5 megohms 1/2 watt	19309-125BF	T25	Same as T19, includes C53, 54, 55, L18, R20, 110 and switch contacts for S1C	31395-G1
S1A, B, C, D	Switch base and spring assembly	31234-G1	T26	Same as T20, includes C56, 57, L19 and switch contacts for S1C	31398-G1
S2	Crystal selector switch.	15879-1			
S3	Crystal switch	31469-1			
S4	Switch, conversion ...	15862-1			
S5A, B, C	Selectivity switch ...	15856-1			
S6	Toggle switch SPST ..	15864-1			
S7	Toggle switch DPST ..	15866-1			
S8	Toggle switch DPDT ..	15867-1			
S9	Same as S6				
S10	Switch "ON-OFF" part of R93	—			
S11	Switch, DPDT, spring return	15880-1			
T1	Mixer plate coil assembly, includes C67, 69, 70, L31, 32, R31	31183-G1			
T2	IF Transformer assembly, includes C97, 98, 99, L33, 34 R35	31116-G2			
T3	Crystal Filter assembly includes C107, 110, 111 112, 113, 114, L36, 37 R41, Y8	31114-G1			
T4	IF Transformer assembly, includes C117, 118, 119, 120, L38, 39, 40, R49	31102-G2			
T5	Same as T4, includes C 123, 124, 125, 126, L41, 42, 43, R54	31102-G2			
T6	Beat Frequency Osc. assembly, includes C130, 131, 132, 133, 134 L44, 45, 46, R76, 77..	31106-G1			
T7	Transformer, Audio Output	31086-2			
T8	Transformer, power ..	31029-2			
T9	3.5 mc Osc. assembly, includes C103, 104, L35, R38, 40, Y7	31131-G1			
T10	RF Input assembly, includes C2, 3, L1 and switch contacts for S1A	31387-G1			

PARTS LIST—Continued

Symbol Designations	DESCRIPTION	Hammarlund Part No.	Symbol Designations	DESCRIPTION	Hammarlund Part No.
T27	Same as T21, includes C58, 59, L20 and switch contacts for S1C	31404-G1	Y7	Crystal, 3.5 mc	31130-1
T28	HF Osc. assembly, includes C76, 77, 78, L25 and switch contacts for S1D	31385-G1	Y8	Crystal, 455 kc	31471-1
T29	HF Osc. assembly, includes C81, 82, L26 and switch contacts for S1D	31388-G1	Miscellaneous	Chart, frequency control	31463-1
T30	HF Osc. assembly, includes C83, 84, 85, L27 and switch contacts for S1D	31391-G1		Dial, band indicator ...	31201-G1
T31	HF Osc. assembly, includes C86, 87, 88, 89, L28 and switch contacts for S1D	31394-G1		Dial, Lamp Socket assembly	31453-1
T32	HF Osc. assembly, includes C90, 91, 92, 93, L29 and switch contacts for S1D	31397-G1		Dial, main tuning	31438-1
T33	HF Osc. assembly, includes C94, 95, 96, L30 and switch contacts for S1D	31403-G1		Dial, vernier tuning ...	31439-1
T34	Crystal control assembly, includes C60, 61, 62, 63, 64, 65, E7, 8, 11, 12, L21, 22, 23, R23, 24, 25, X3, 21 to 26	31409-G1		Fuse Holder	15923-1
X1-2	Tube socket, miniature	15989-4		Knob and Dial (Audio Gain)	31227-G2
X3	Tube socket, octal	16082-1		Knob and Dial (Beat Freq. Osc.)	31227-G4
X4	Tube socket, miniature ceramic, less center shield	15989-5		Knob and Dial (Crystal Phasing)	31227-G3
X5	Tube socket, miniature ceramic, with center shield	15989-3		Knob and Dial (RF Gain)	31227-G1
X6 to 15	Same as X1			Knob and Dial (Selectivity)	31227-G5
X16	Tube socket, noval	16100-1		Knob and Skirt (large) ..	31215-G1
X17	Same as X3			Knob, frequency control	31434-G1
X18	Same as X1			Knob, tuning lock	31462-G1
X19	Same as X3			Knurled thumb screw ...	31495-1
X20	Same as X1			Shaft Coupling, rigid ..	31275-G1
X21 to 26	Crystal socket, ceramic, for crystals Y1 to Y6.	16092-5		Shaft Coupling, flexible soft	415-G3
Y1 to 6	Crystal, CR-18/U, see note below	31473-spec		Shaft Coupling, flexible stiff	415-G2
				Snap Button Plug	29619-2
				Spare fuse cover	31494-1
				Spring, anti-blacklash ..	31239-1
				Spring, Band Change Detent	31205-1
				Spring, Conversion Switch	31125-1
				Spring, Crystal Retaining	31417-1
				Spring, IF adjuster grounding	31023-1
				Spring, Indicator Slide ..	31126-1
				Spring, Retainer for RF Coils	31004-1
				Spring, Retainer for RF Coil assemblies	31003-1
				Window, Band Indicator	31282-1
				Window, Tuning Dials ..	31281-1
				Wrench, Set Screw No. 6	11806-2
				Wrench, Set Screw No. 8	11806-3
				Wrench, Set Screw No. 10	11806-4

NOTE: Crystals supplied on special order, per Hammarlund Specification No. 31473, for use in the Crystal Frequency Control Unit, see page 8, shall be made in accordance with Signal Corps Specification CR-18/U. The frequency tolerance shall be within plus or minus .005%. The holder shall be in accordance with HC-6/U or CR-7.

The *Signal Frequency* for which the crystal is to be used shall be stamped on the top of the holder.

The oscillator or actual crystal frequency for a given signal frequency shall be determined from the following:

<i>Signal Frequency MC</i>	<i>Add IF Frequency MC</i>	<i>Mode of Operation</i>
00.75000 to 07.39999	0.455000	Fundamental
07.40000 on 3.45 to 7.40 band	0.455000 (see note below)	Fundamental
07.40000 on 7.40 to 14.8 band	3.955000 (see note below)	Fundamental
07.40001 to 12.04499	3.955000	Fundamental
12.0450 to 44.04499	3.955000 and divide sum by 3	3rd Harmonic ✓
44.0450 to 54.00000	3.955000 and divide sum by 4	4th Harmonic

NOTE: Since 7.40 mc is the signal frequency at which the intermediate frequency is changed for double conversion and since this signal frequency occurs at the high frequency end of the 3.45 to 7.40 mc

band and also at the low frequency end of the 7.40 to 14.8 mc band, it is necessary to specify frequency band as well as Signal Frequency when ordering crystals for exactly 7.40 mc signal operation.

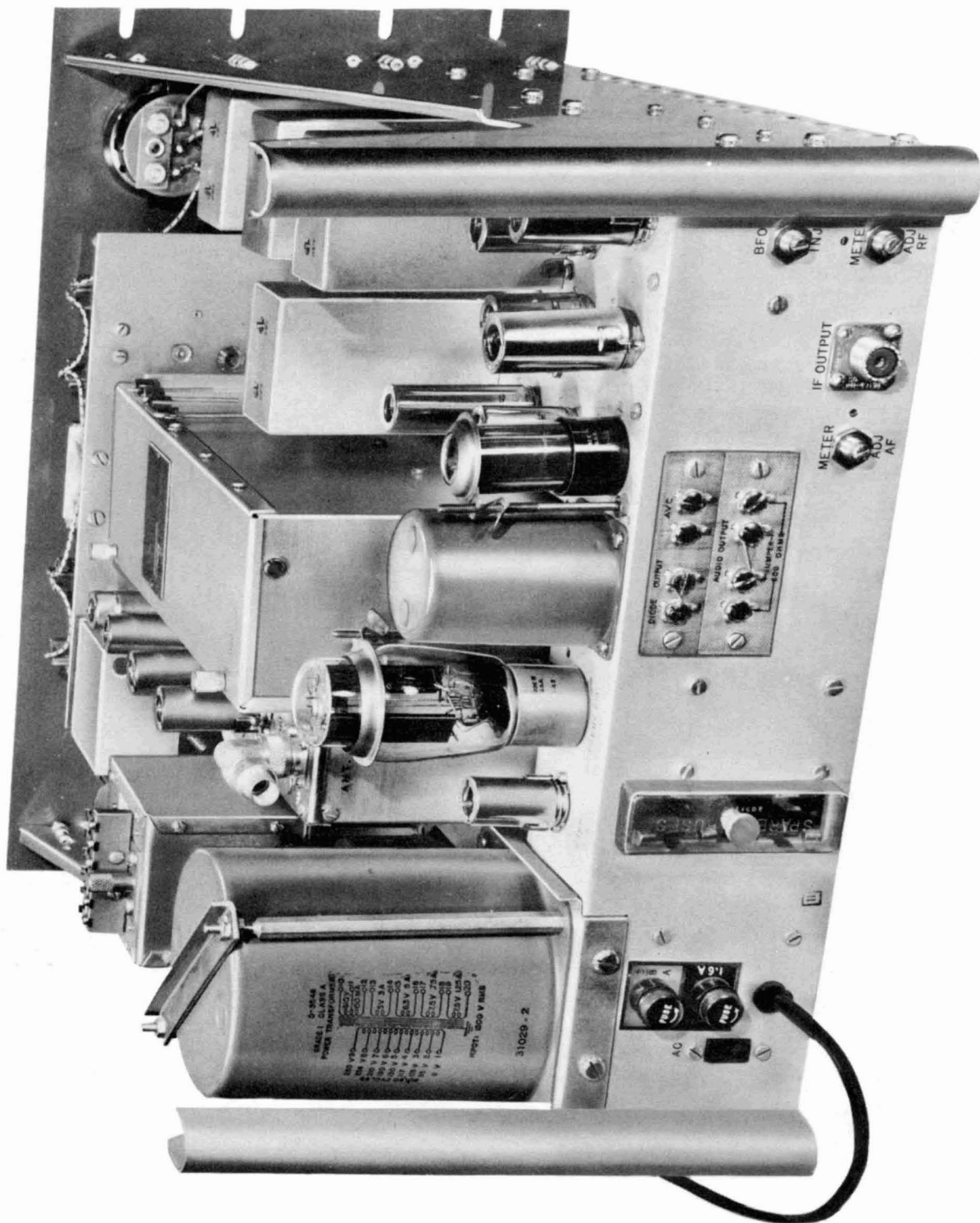

FIG. 6
REAR VIEW OF RECEIVER

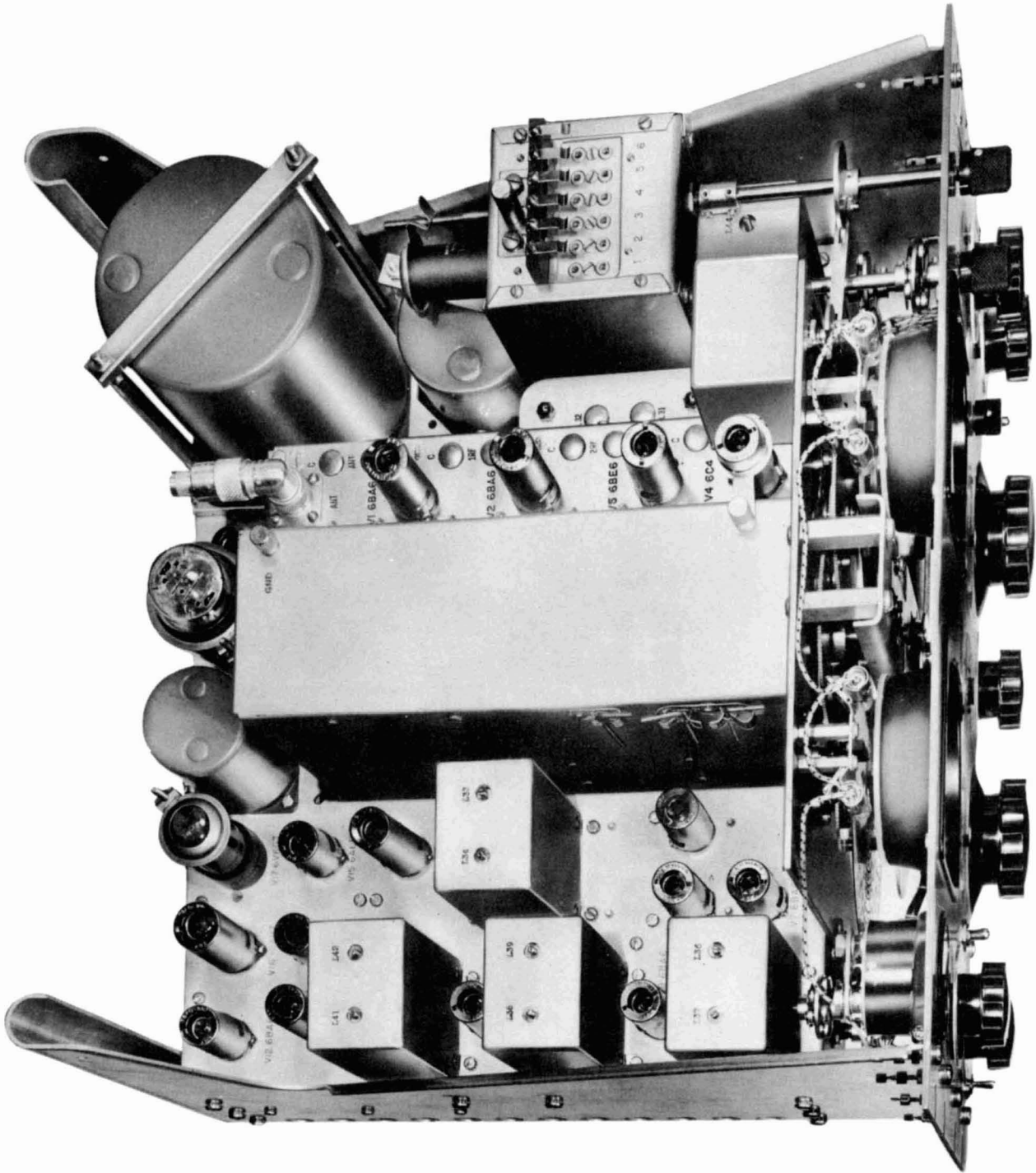

FIG. 7
TOP VIEW OF RECEIVER

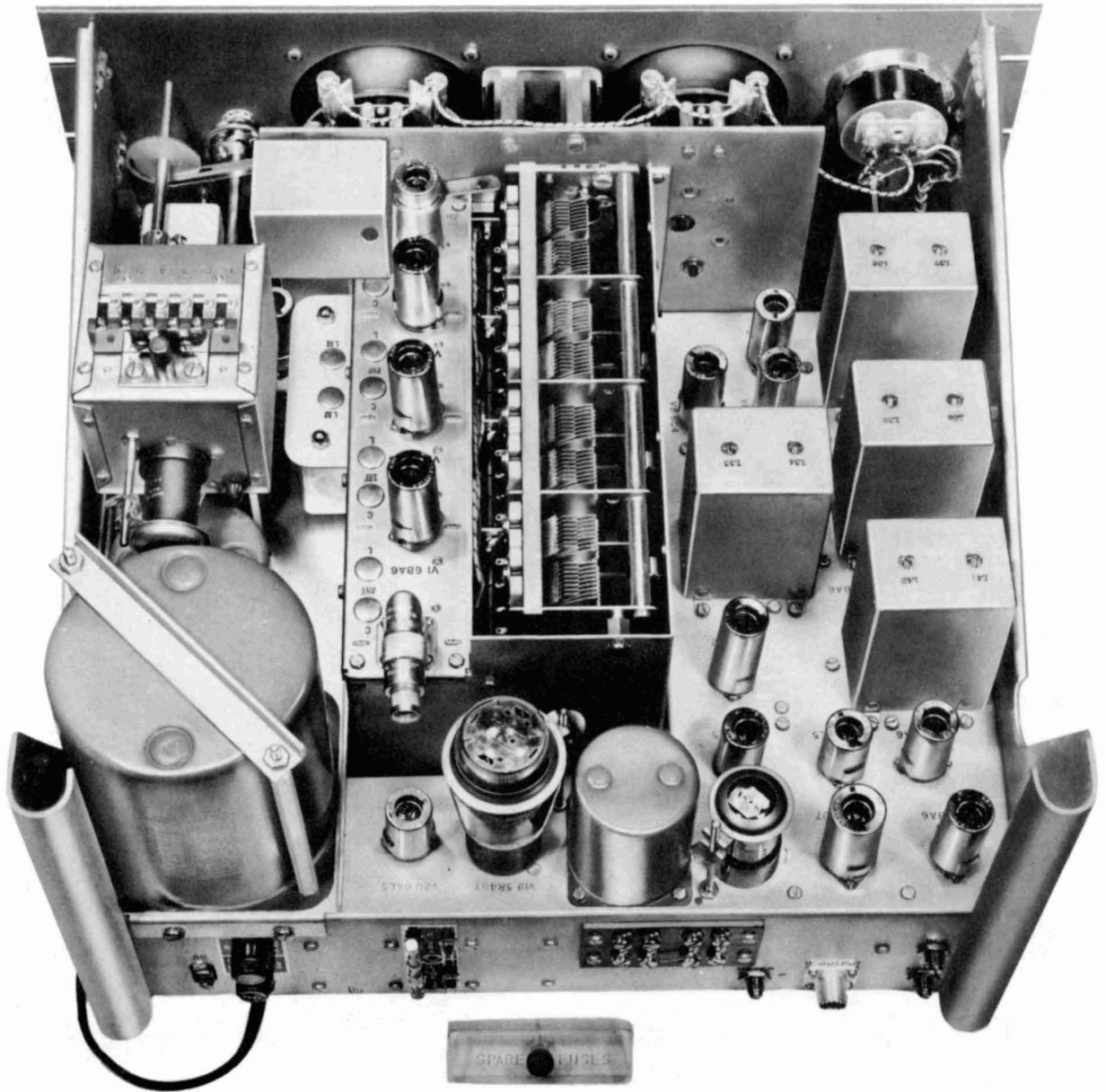

FIG. 8
TOP VIEW OF RECEIVER
CAPACITOR SHIELD AND SPARE FUSE COVER REMOVED

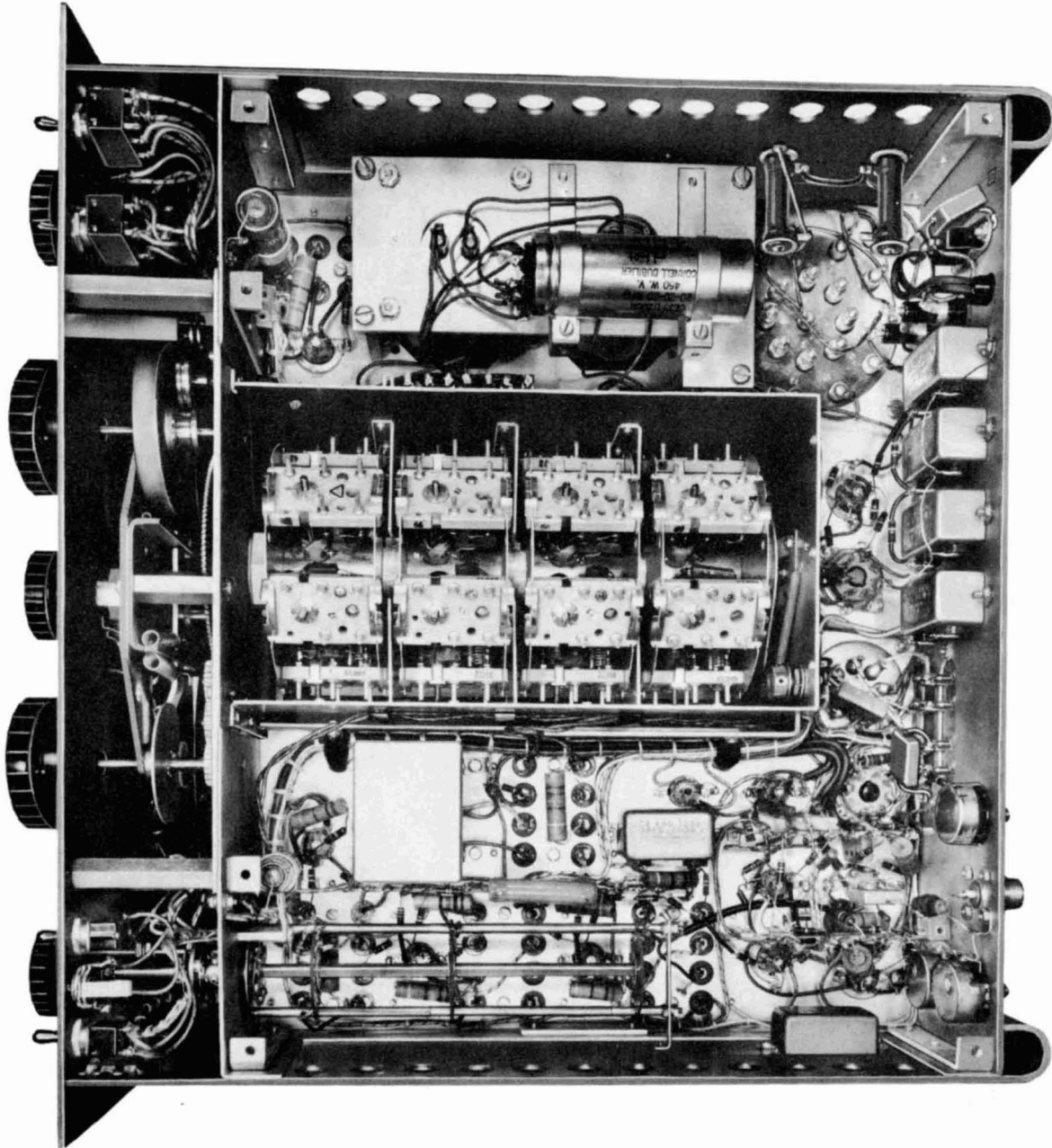

FIG. 9
BOTTOM VIEW OF RECEIVER
TUNING UNIT SHIELD REMOVED

Note 1: T2—IF Transformer—31116-G1, used in earlier models, contained R94, Resistor, 1100 ohms, 1/2 watt—19309-208BF. This resistor is omitted in 31116-G2 and is re-located on E-13. This should be checked when making replacement of T2.

Note 2: Items C163, R48, R94, R115 and R116 are located on E13. Items C165 and R53 are located on the front end of E17.

Note 3: Ignore items C163, R48 and R53.

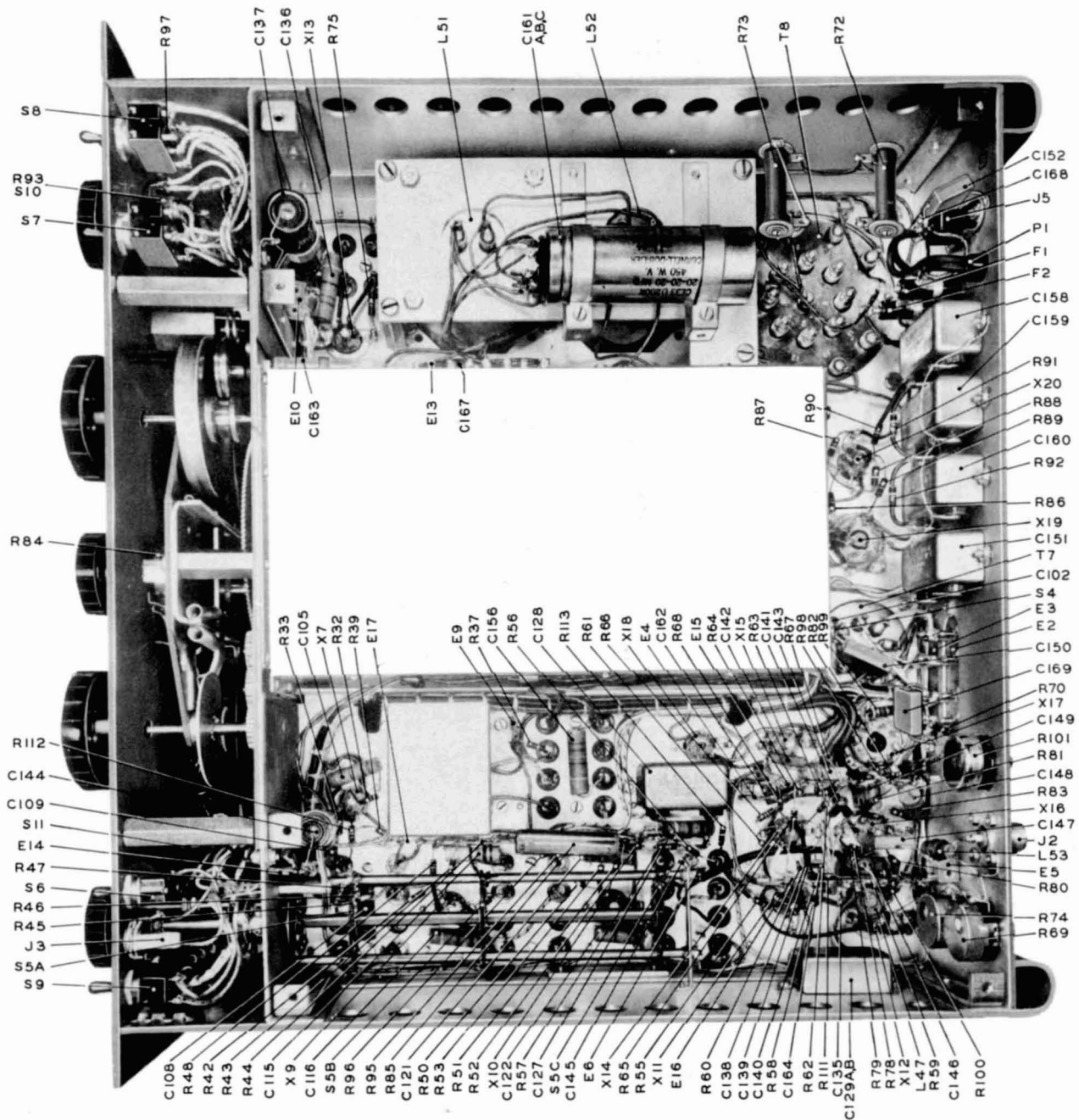

FIG. 10
BOTTOM VIEW OF RECEIVER SP-600-JX

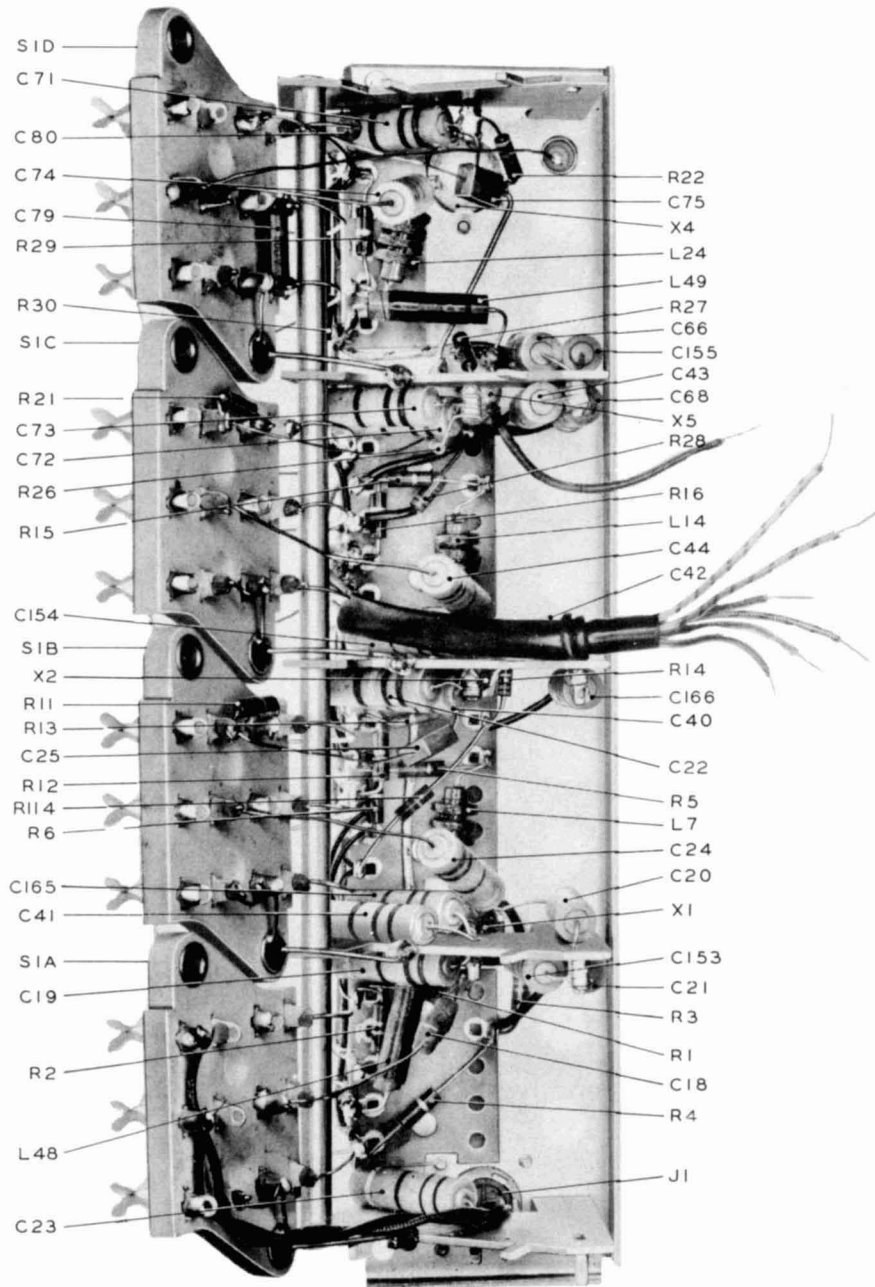

FIG. II
BOTTOM VIEW OF RF PLATFORM

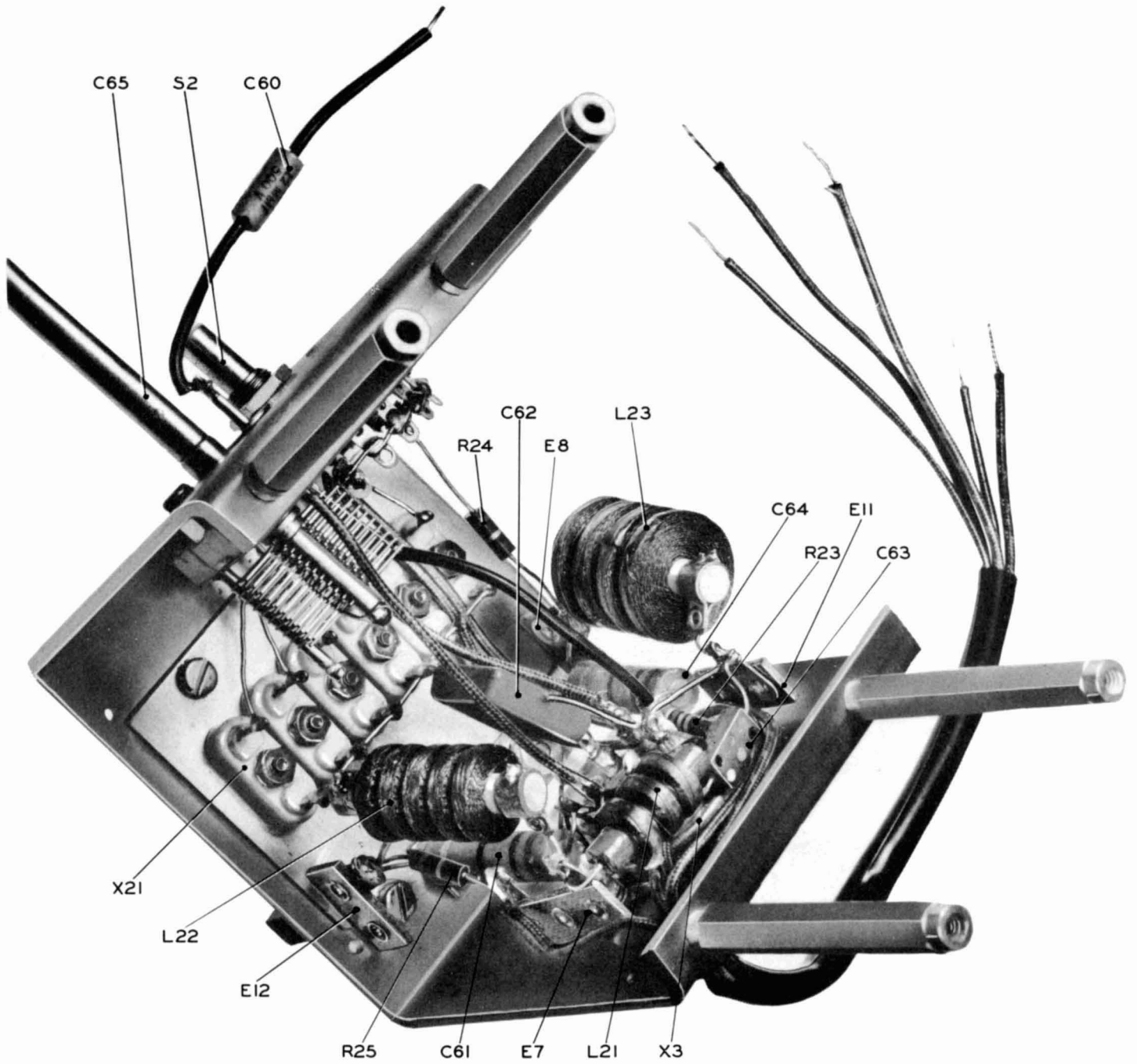
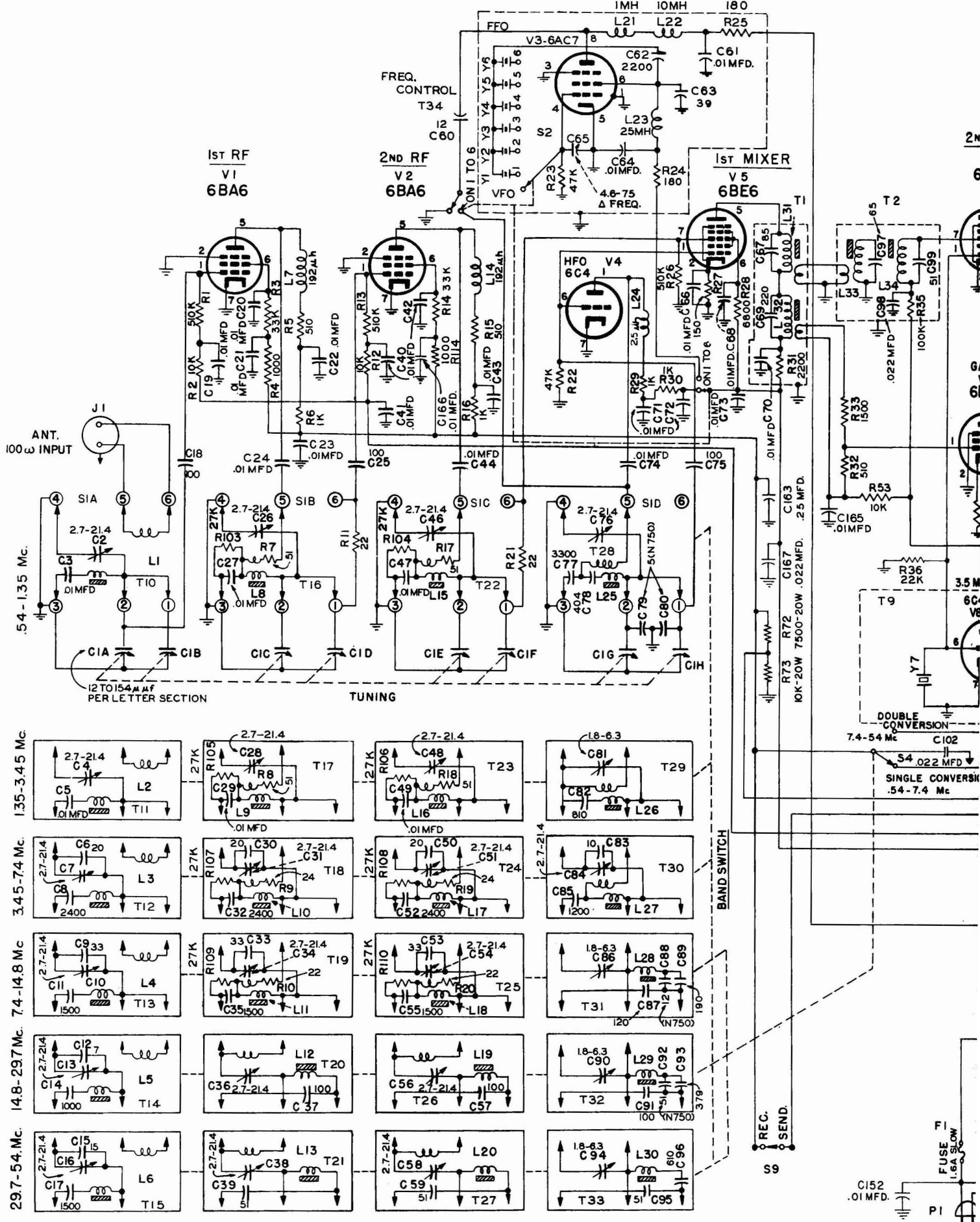

FIG. 12
BOTTOM VIEW OF FREQUENCY CONTROL UNIT



54-135 Mc.

135-3.45 Mc.

3.45-7.4 Mc.

7.4-14.8 Mc.

14.8-29.7 Mc.

29.7-54 Mc.

1st RF
V1
6BA6

2nd RF
V2
6BA6

1st MIXER
V5
6BE6

HF
V4
6C4

ANT.
100Ω INPUT

12 TO 154 μF
PER LETTER SECTION

TUNING

BAND SWITCH

DOUBLE CONVERSION
7.4-54 Mc
C102
54.022 MFD
SINGLE CONVERSION
.54-7.4 Mc

REC.
SEND.
S9

C152
.01 MFD.

FUSE
1.6A SLOW

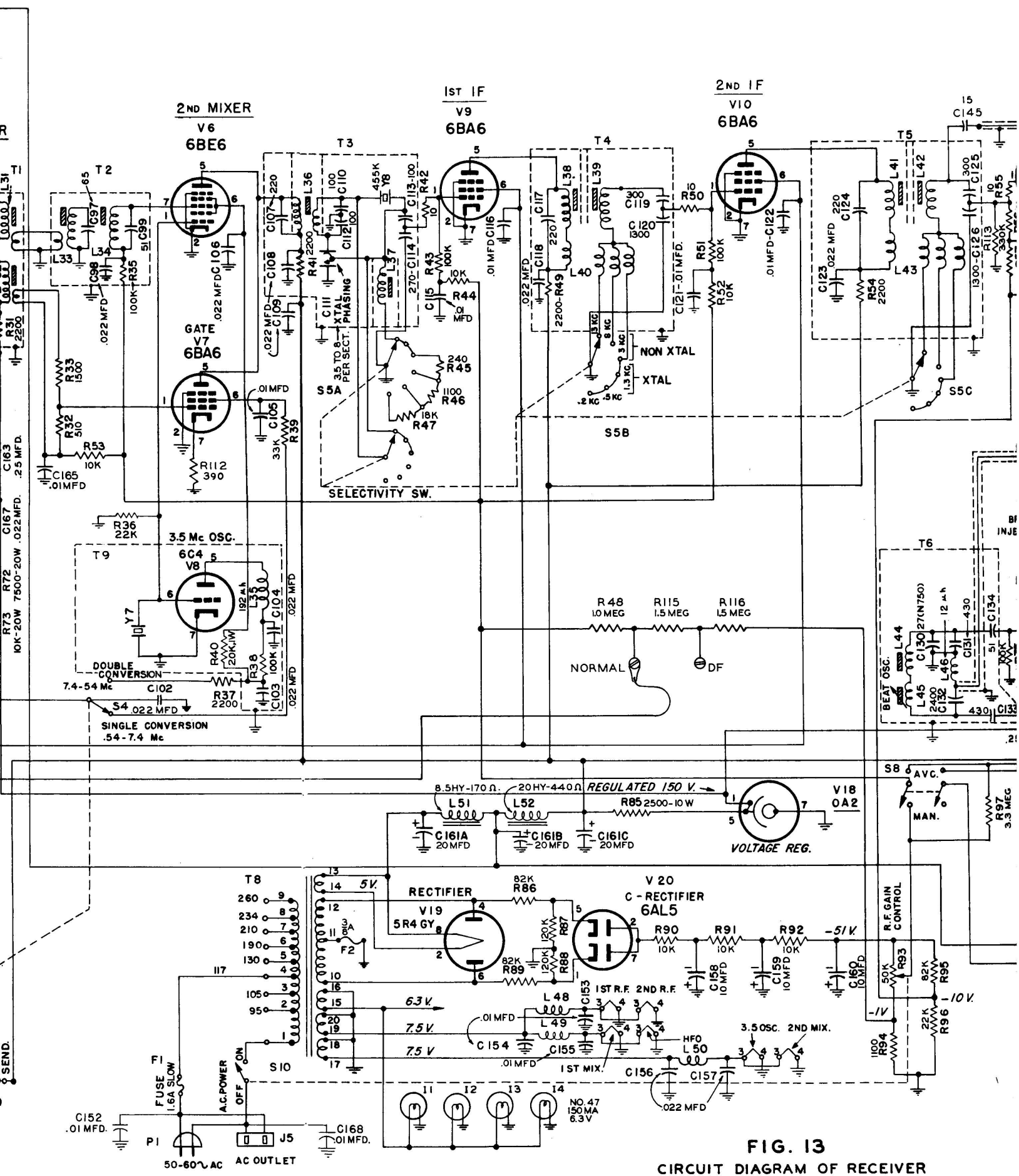

FIG. 13
CIRCUIT DIAGRAM OF RECEIVER

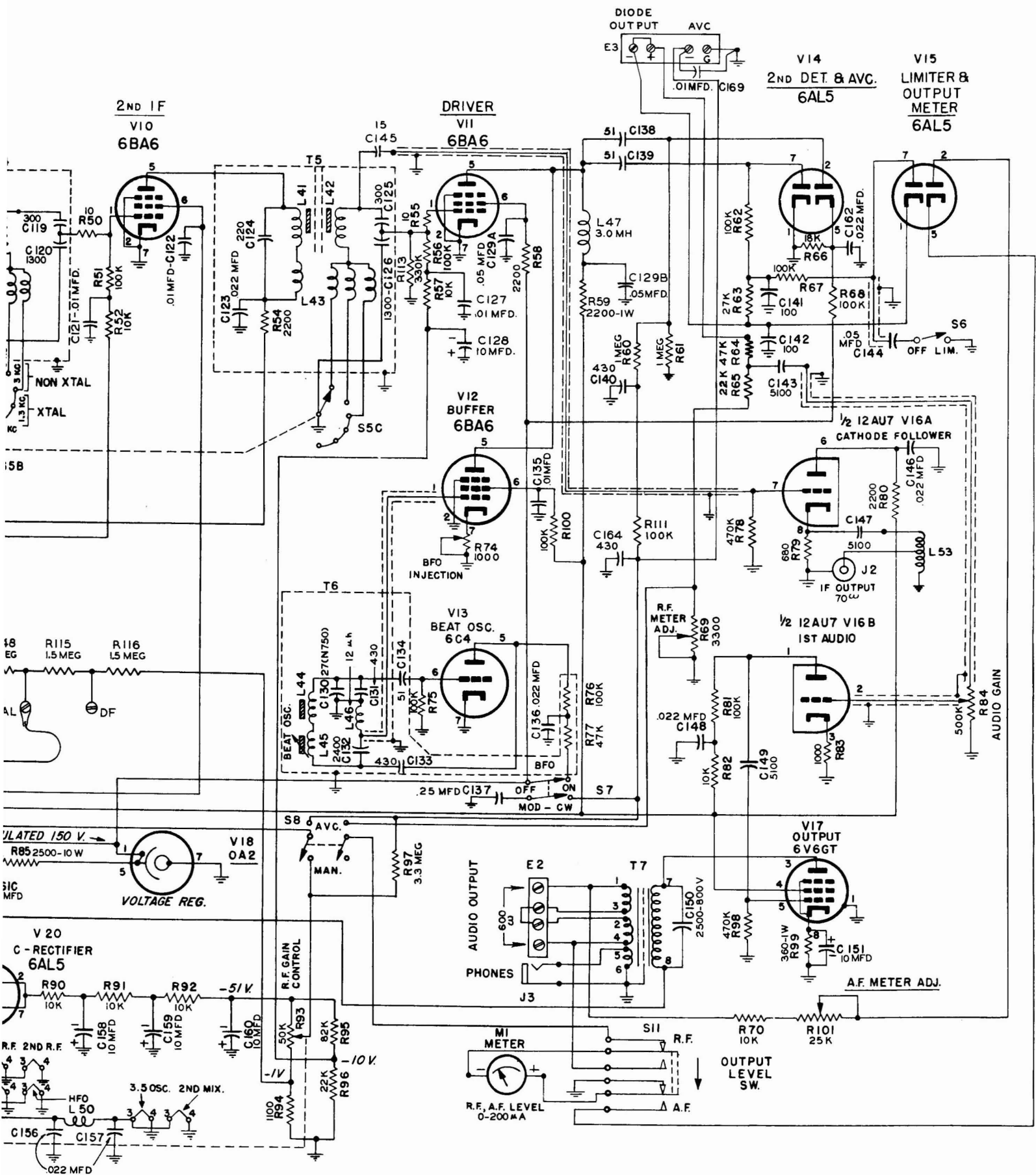

FIG. 13
CIRCUIT DIAGRAM OF RECEIVER

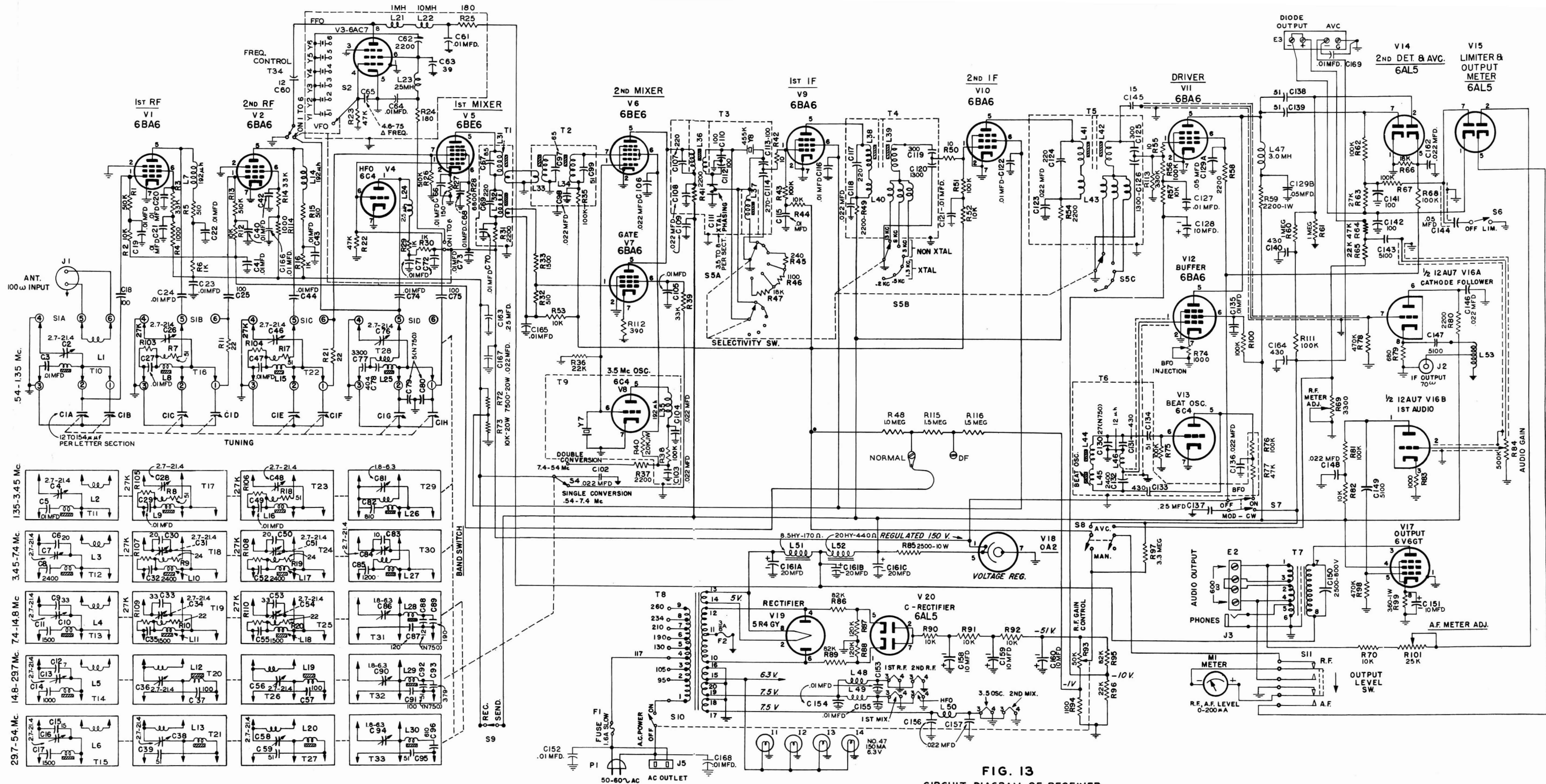
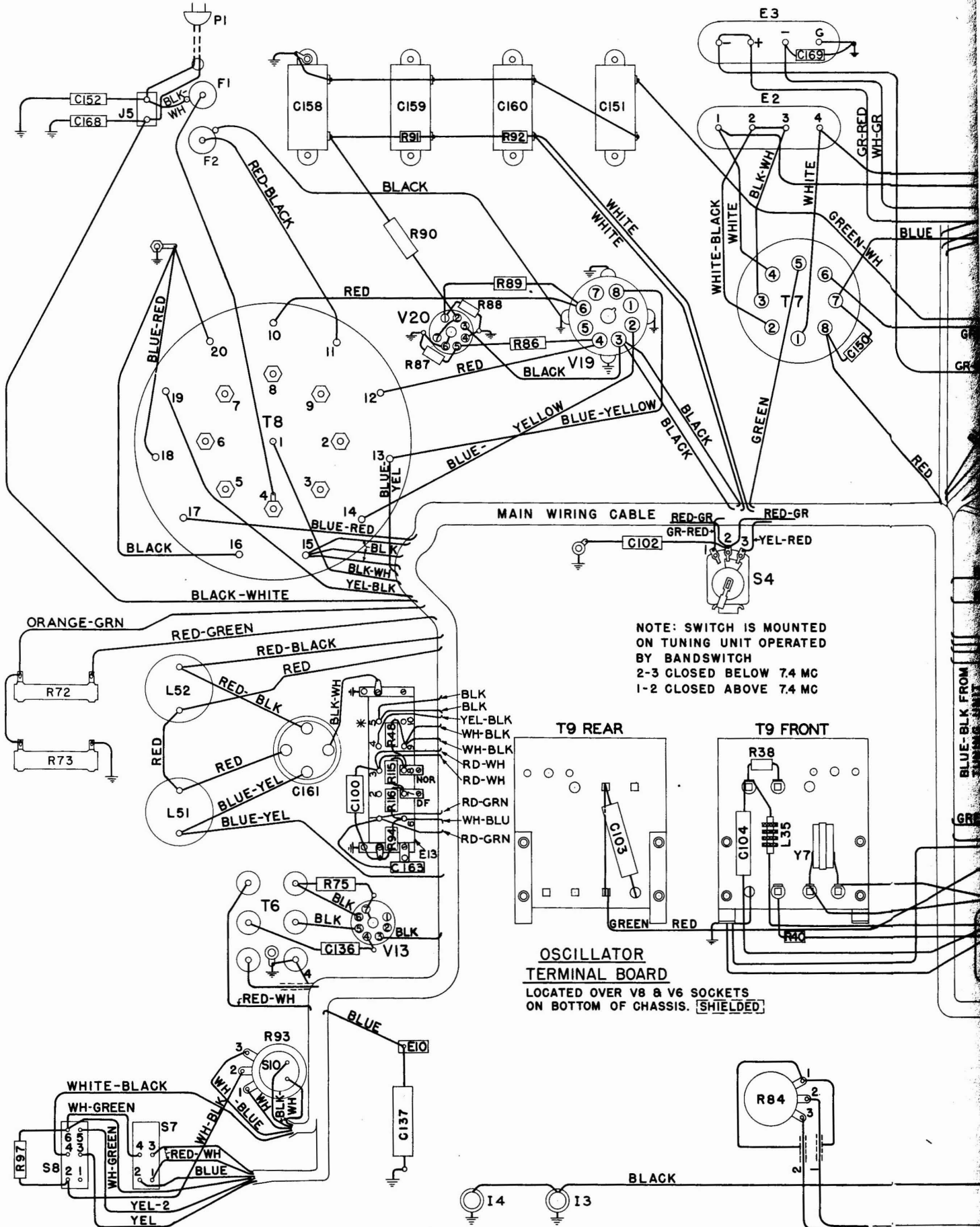

FIG. 13
CIRCUIT DIAGRAM OF RECEIVER



NOTE: SWITCH IS MOUNTED ON TUNING UNIT OPERATED BY BANDSWITCH
 2-3 CLOSED BELOW 7.4 MC
 1-2 CLOSED ABOVE 7.4 MC

OSCILLATOR TERMINAL BOARD

LOCATED OVER V8 & V6 SOCKETS ON BOTTOM OF CHASSIS. SHIELDED

BLUE-BLK FROM TUNING UNIT

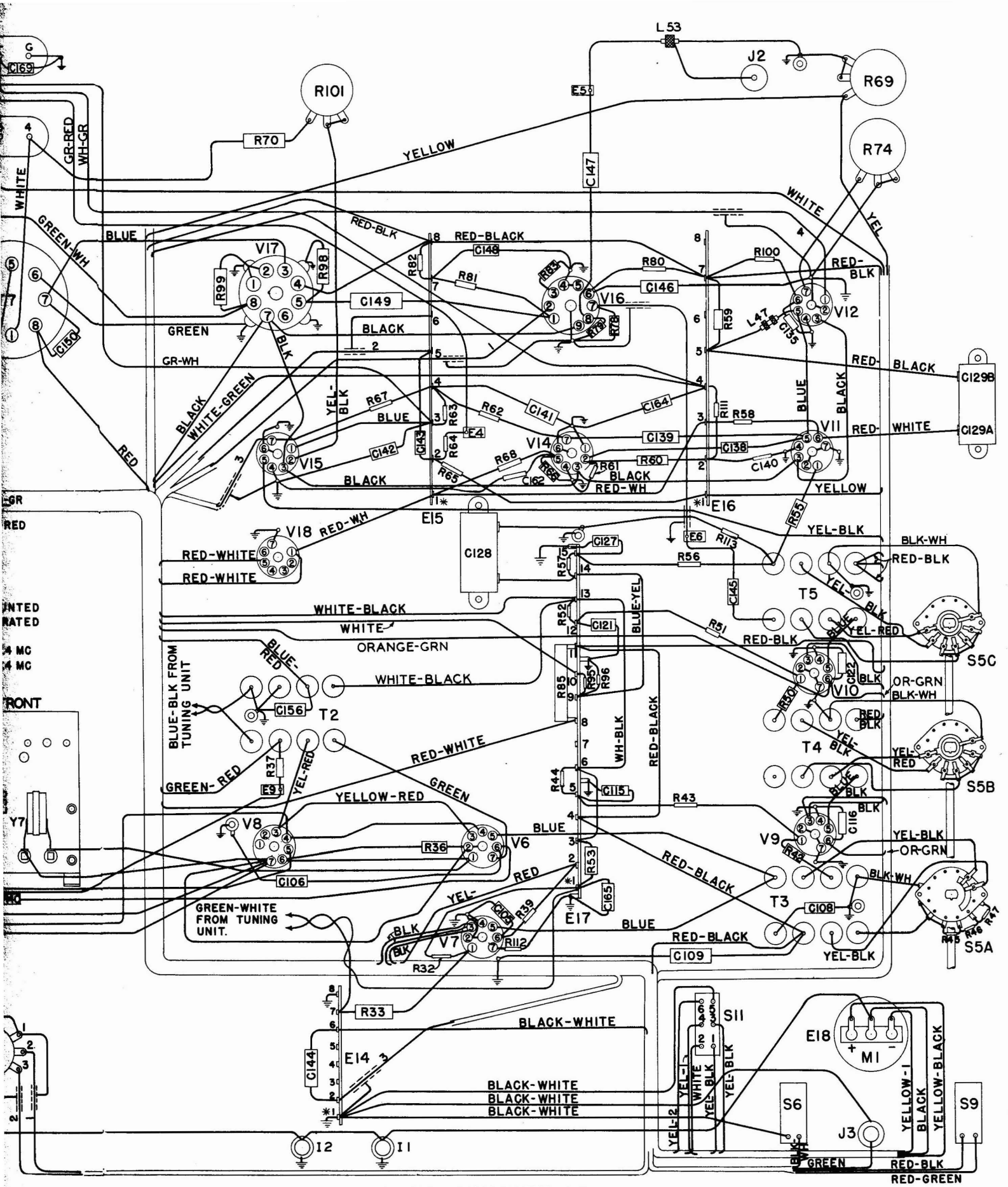

FIGURE NUMBER 14
CONNECTION DIAGRAM-RECEIVER CHASSIS

* THESE NUMBERS ARE FOR REFERENCE ONLY. THEY DO NOT APPEAR ON TERMINAL STRIP.

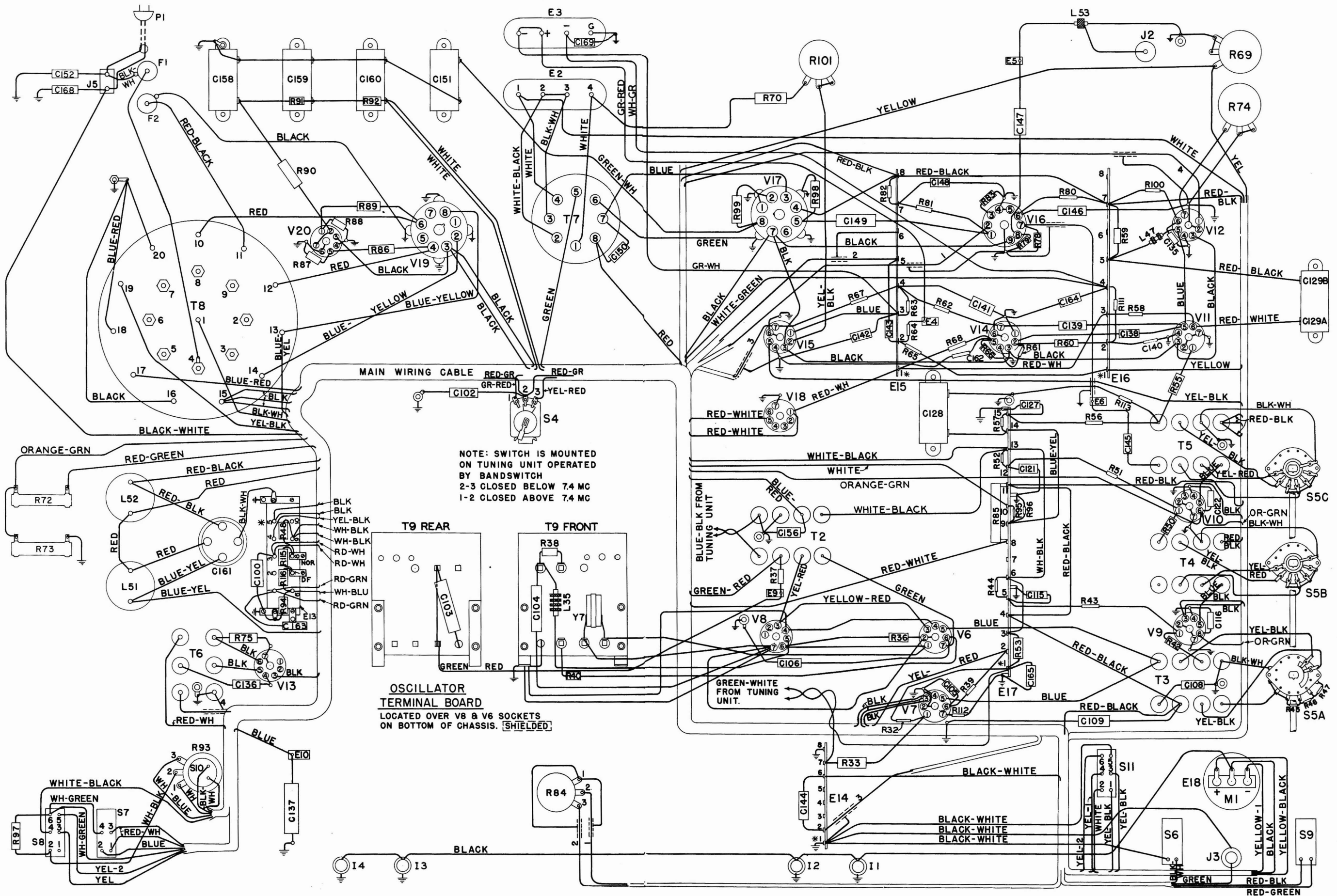

FIGURE NUMBER 14
CONNECTION DIAGRAM-RECEIVER CHASSIS

* THESE NUMBERS ARE FOR REFERENCE ONLY. THEY DO NOT APPEAR ON TERMINAL STRIP.

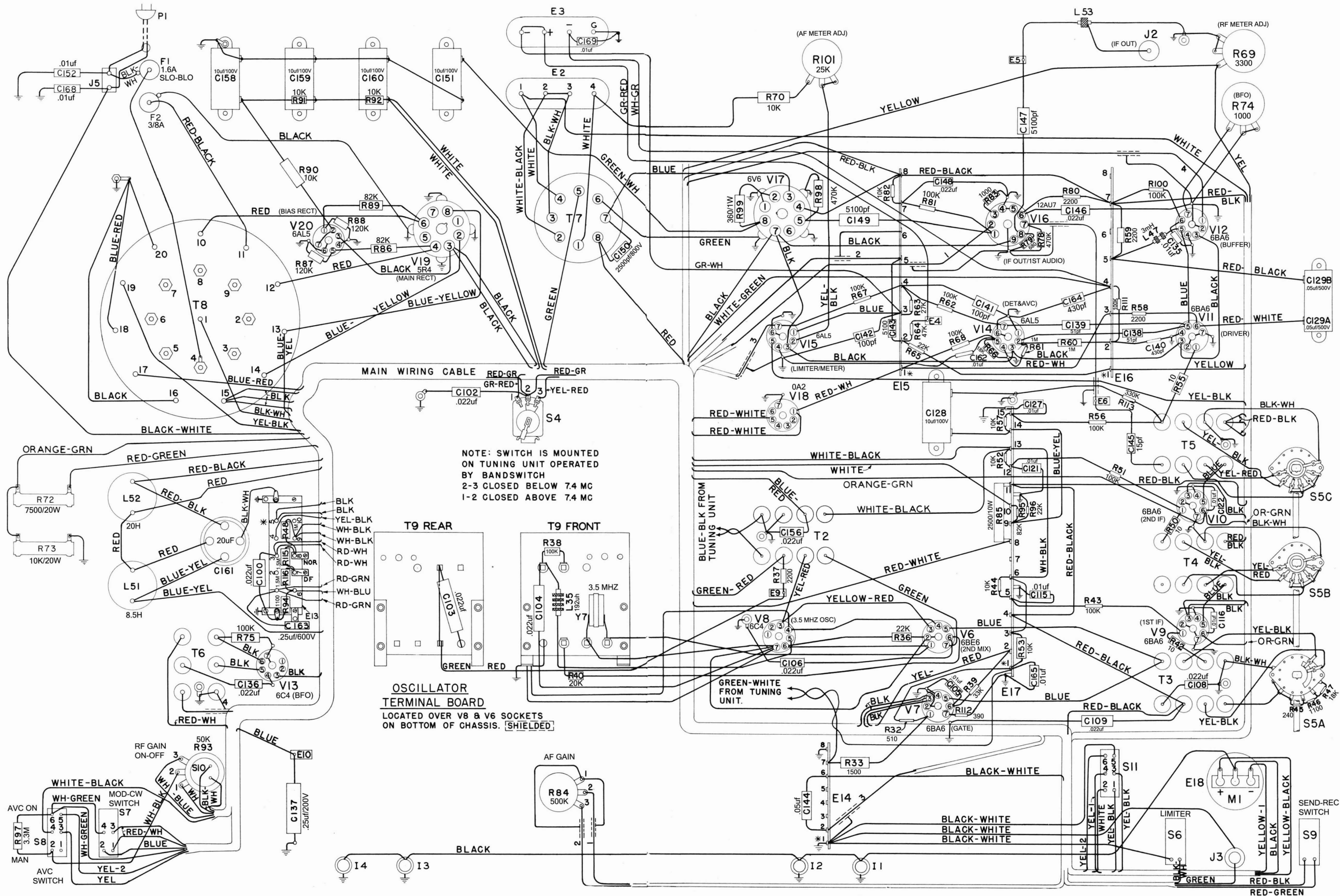

FIGURE NUMBER 14
CONNECTION DIAGRAM-RECEIVER CHASSIS

* THESE NUMBERS ARE FOR REFERENCE ONLY. THEY DO NOT APPEAR ON TERMINAL STRIP.

[37]

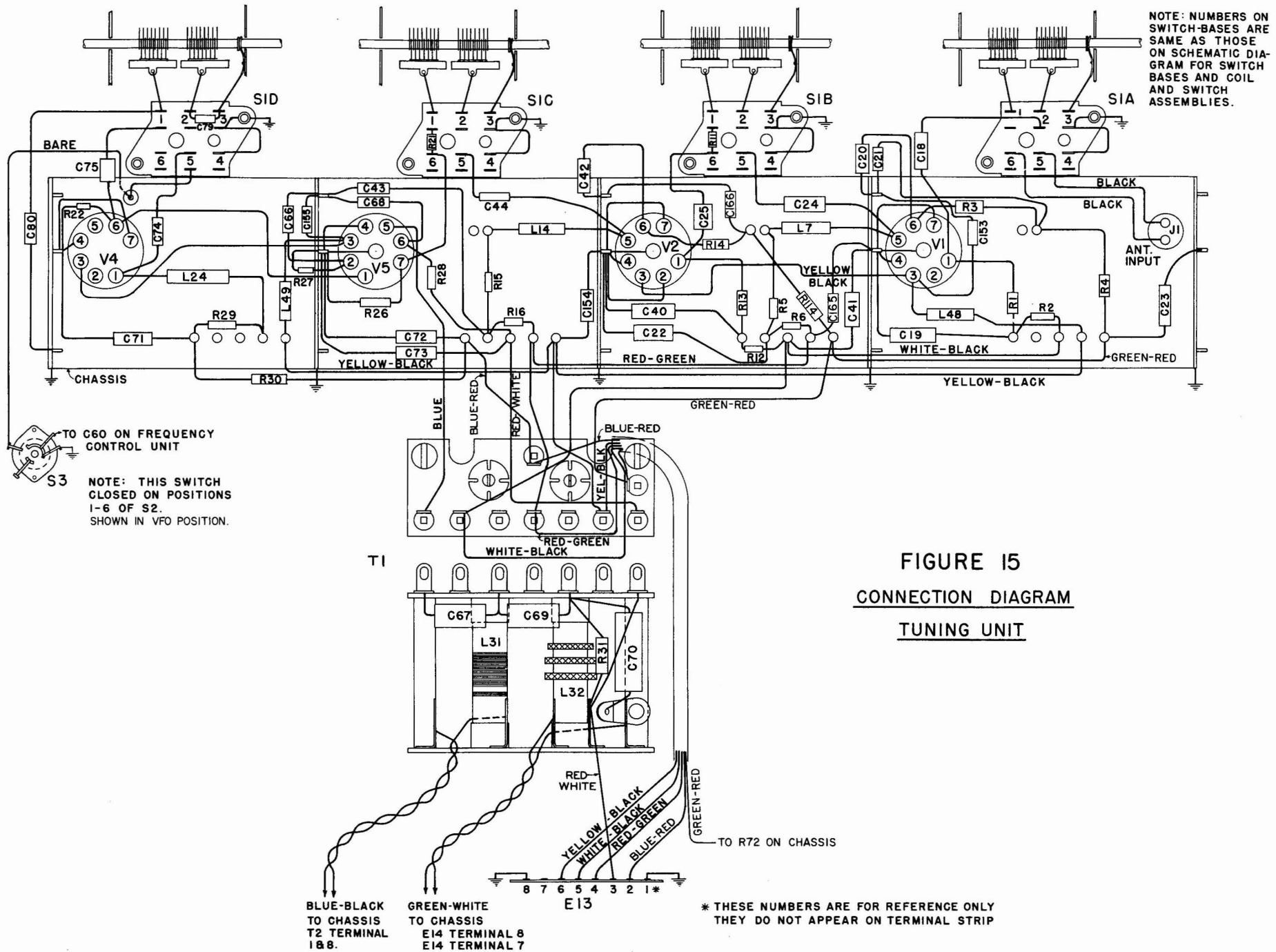

FIGURE 15
CONNECTION DIAGRAM
TUNING UNIT

BLUE-BLACK
TO CHASSIS
T2 TERMINAL
1 & 8.

GREEN-WHITE
TO CHASSIS
E14 TERMINAL 8
E14 TERMINAL 7

* THESE NUMBERS ARE FOR REFERENCE ONLY
THEY DO NOT APPEAR ON TERMINAL STRIP

[37]

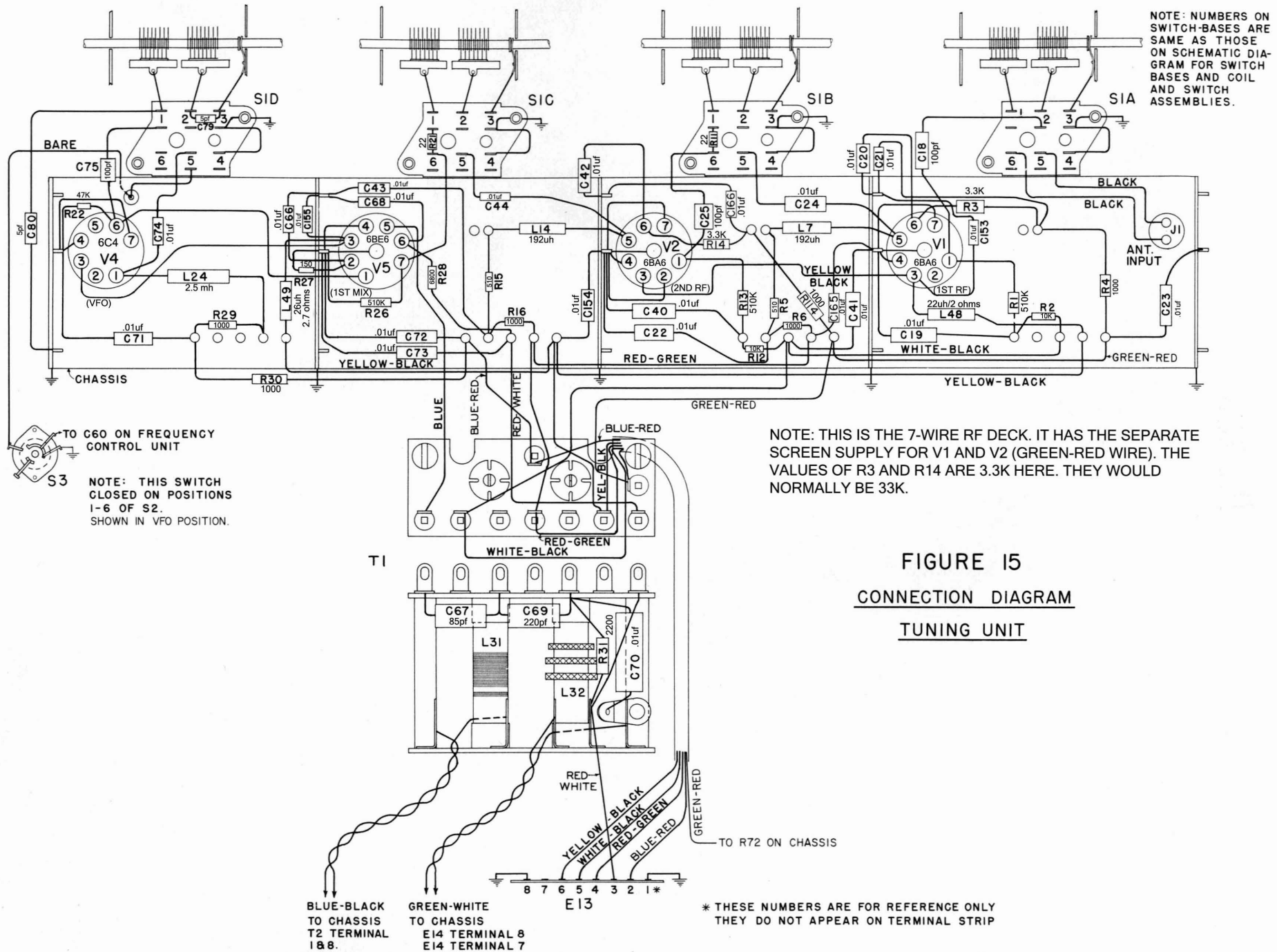

NOTE: NUMBERS ON SWITCH-BASES ARE SAME AS THOSE ON SCHEMATIC DIAGRAM FOR SWITCH BASES AND COIL AND SWITCH ASSEMBLIES.

NOTE: THIS IS THE 7-WIRE RF DECK. IT HAS THE SEPARATE SCREEN SUPPLY FOR V1 AND V2 (GREEN-RED WIRE). THE VALUES OF R3 AND R14 ARE 3.3K HERE. THEY WOULD NORMALLY BE 33K.

FIGURE 15
CONNECTION DIAGRAM
TUNING UNIT

NOTE: THIS SWITCH CLOSED ON POSITIONS 1-6 OF S2. SHOWN IN VFO POSITION.

* THESE NUMBERS ARE FOR REFERENCE ONLY THEY DO NOT APPEAR ON TERMINAL STRIP

BLUE-BLACK TO CHASSIS T2 TERMINAL 1 & 8.
GREEN-WHITE TO CHASSIS E14 TERMINAL 8 E14 TERMINAL 7

Notes

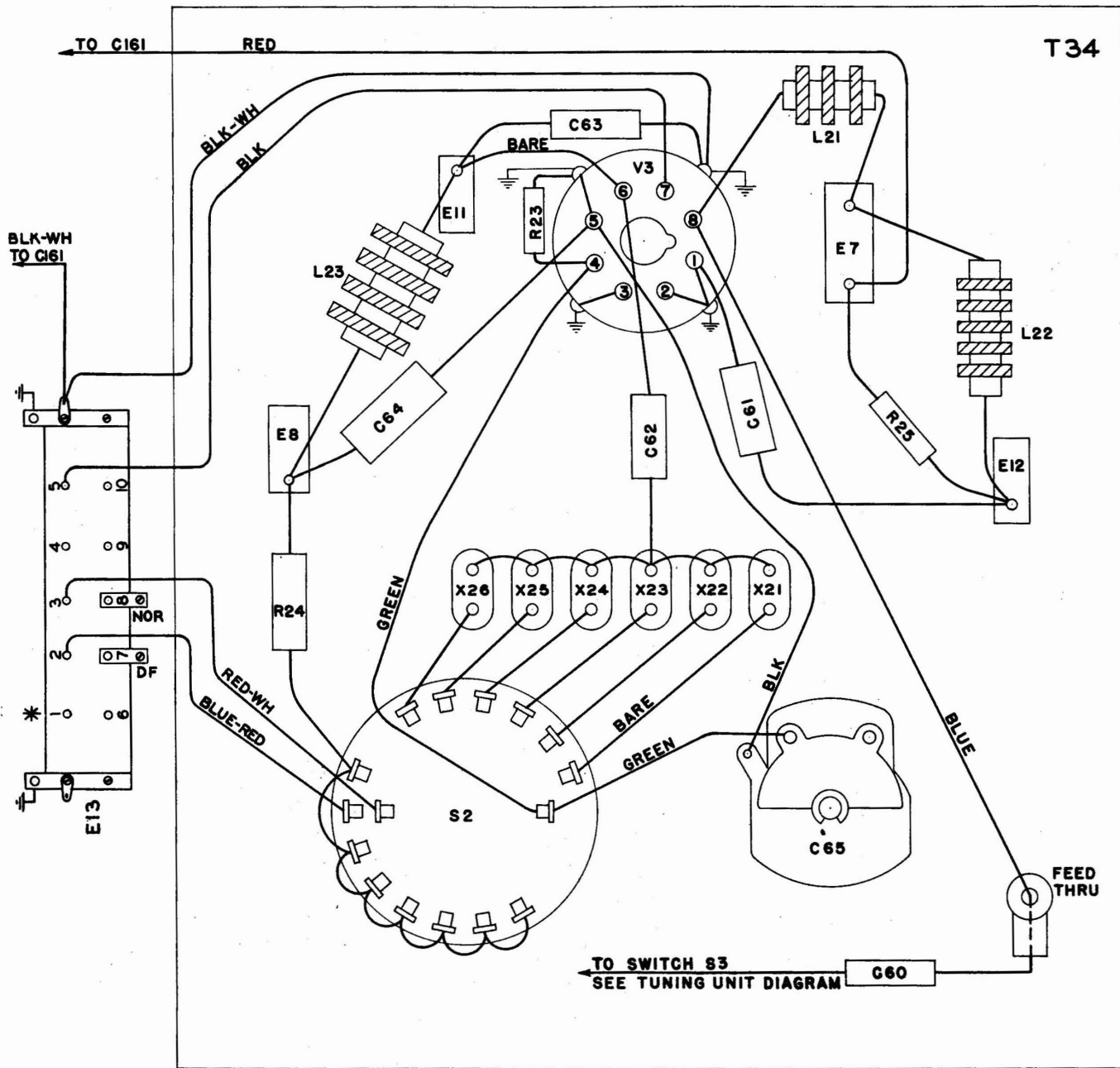

* THESE NUMBERS ARE FOR REFERENCE ONLY.
 THEY DO NOT APPEAR ON TERMINAL STRIP.

FIGURE 16
CONNECTION DIAGRAM
FREQUENCY CONTROL UNIT

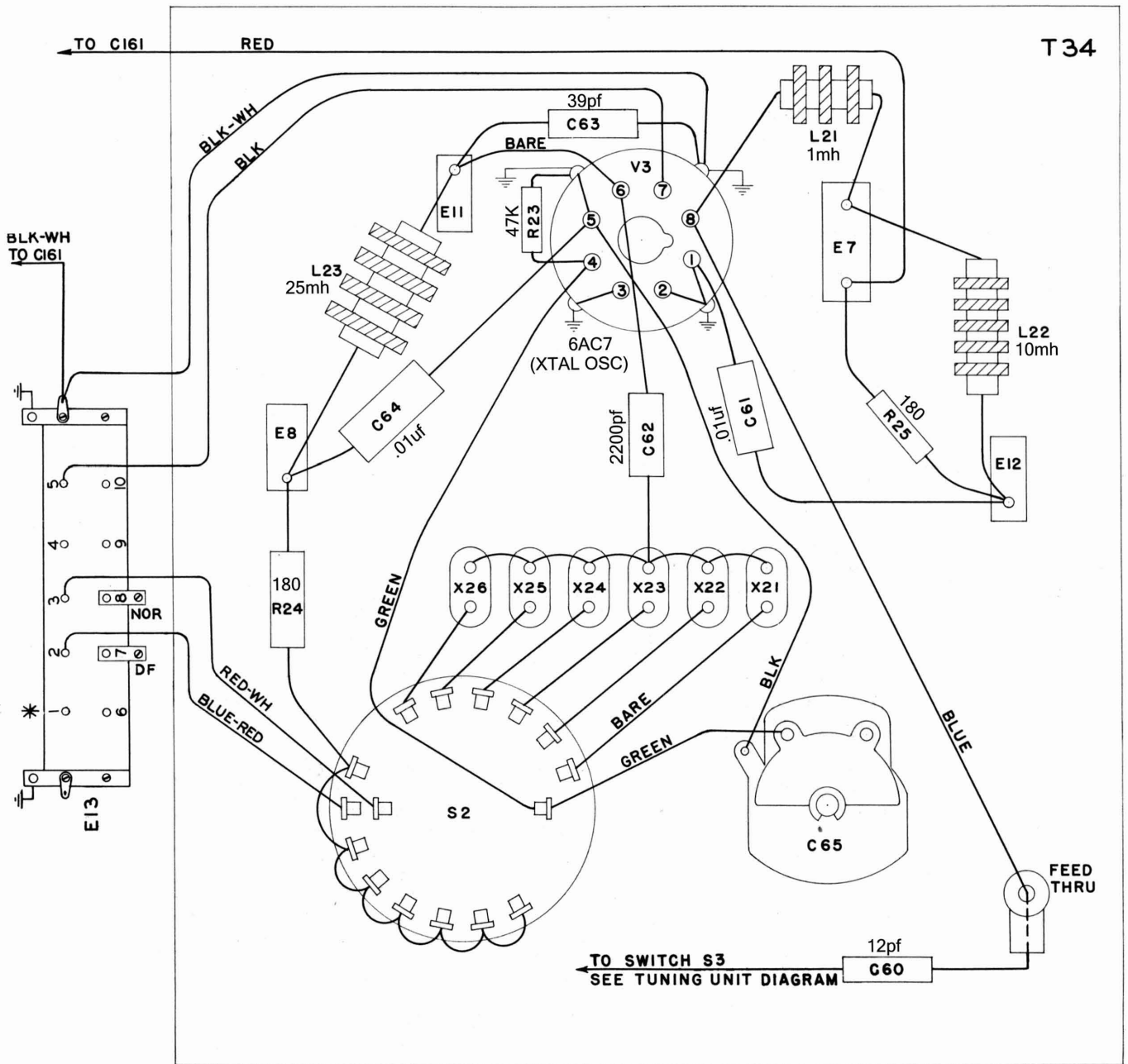

FIGURE 16
CONNECTION DIAGRAM
FREQUENCY CONTROL UNIT

VII

SUPPLEMENT FOR USE WITH MODELS SP-600-JL AND SP-600-JLX

Frequency Range — Models SP-600-JL and SP-600-JLX have a frequency range of .100 to .400 mc and 1.35 to 29.7 mc in six bands as follows:

- .100 to .200 mc
- .200 to .400 mc
- 1.35 to 3.45 mc
- 3.45 to 7.40 mc
- 7.40 to 14.8 mc
- 14.80 to 29.7 mc

Crystal Frequency Control — Model SP-600-JL does not have the Frequency Control Unit. All indications in the text, photographs and diagrams, with reference to the Frequency Control Unit, should be ignored as they do not apply to Model SP-600-JL.

Model SP 600-JLX includes the Crystal Frequency Control Unit as described in the text.

Alignment of the RF Amplifier and HF Oscillator — With reference to alignment of the RF Amplifier and HF Oscillator, see page 13, the alignment frequencies for the .100 to .200 mc and .200 to .400 mc bands are:

For the .100 to .200 mc band; Adjust L at .100 mc and adjust C at .200 mc.

For the .200 to .400 mc band; Adjust L at .200 mc and adjust C at .400 mc.

Parts List Errata and Addenda for SP-600-JL and SP-600-JLX — With reference to Table No. 5, pages 23 and 24

Delete Items T10, 16, 22 and T28 (coil assemblies for 54 to 1.35 mc band).

Delete Items T15, 21, 27 and T33 (coil assemblies for 29.7 to 54.0 mc band).

Add to Parts List the following, for the .100 to .200 mc and .200 to .400 mc bands:

In Position of	DESCRIPTION	Hammarlund Part No.
T10	RF Input assembly, .100 to .200 mc, includes C2 trimmer, 43 mmf fixed shunt capacitor Pt. No. 23063-68C, coil and switch contacts for S1A.....	31381-G1
T16	1st RF Transformer assembly, .100 to .200 mc, includes C26 trimmer, 43 mmf fixed shunt capacitor Pt. No. 23063-68C, coil and switch contacts for S1B..	31380-G2
T22	2nd RF Transformer assembly, .100 to .200 mc, includes C46 trimmer, 43 mmf fixed shunt capacitor Pt. No. 2E063-68C, coil, 200,000 ohm 1/2 watt fixed shunt resistor Pt. No. 19309-182BF and switch contacts for S1C.....	31380-G1
T28	HF Osc. assembly, .100 to .200 mc, includes C76 trimmer, 75 mmf fixed shunt capacitor Pt. No. 23003-91C, 102 mmf fixed series padder capacitor Pt. No. 23071-65, coil and switch contacts for S1D.....	31379-G1
T15	RF Input assembly, .200 to .400 mc, includes C16 trimmer, 43 mmf fixed shunt capacitor Pt. No. 23063-68C, coil and switch contacts for S1A.....	31384-G1
T21	1st RF Transformer assembly, .200 to .400 mc, includes C38 trimmer, 43 mmf fixed shunt capacitor Pt. No. 23063-68C, coil and switch contacts for S1B..	31383-G2
T27	2nd RF Transformer assembly, .200 to .400 mc, includes C58 trimmer, 43 mmf fixed shunt capacitor Pt. No. 23063-68C, coil, 200,000 ohm 1/2 watt fixed shunt resistor Pt. No. 19309-182BF and switch contacts for S1C.....	31383-G1
T33	HF Osc. assembly, .200 to .400 mc, includes C94 trimmer, 68 mmf fixed shunt capacitor Pt. No. 23003-90C, 204 mmf fixed series padder capacitor Pt. No. 23071-66, coil and switch contacts for S1D.....	31382-G1

SUPPLEMENT FOR USE WITH MODEL SP-600-J (25 CYCLES)

This Receiver-Model SP-600-J25 (25 cycles) does not have the Frequency Control Unit. All indications in the text, photographs and diagrams, with reference to the Frequency Control Unit, should be ignored as they do not apply to Model SP-600-J.

The Power Transformer used in this model is specially designed for operation on a single phase 25 cycle power line and will operate satisfactorily on power line frequencies from 25 to 60 cycles. Eight screw terminal primary voltage taps are provided. These taps cover a power line source range of 90 to 270

volts. The 117 volt tap is connected when the receiver is shipped from the manufacturer. When the receiver is installed for operation make sure that the primary tap lead on the power transformer is connected to the transformer tap which most nearly agrees with the power source voltage.

The manufacturer's part number for the 25 cycle power transformer, T8, is 31029-3. With the above exceptions this receiver is the same as Model SP-600-JX in all respects.

